

# RUD CONVEYOR SYSTEMS

FOR HORIZONTAL, VERTICAL AND INCLINED CONVEYORS



## DO YOU EXPERIENCE ANY OF THESE CONVEYOR ISSUES?

## CONTENTS



**Is your chain equipment wearing out too quickly?**  
The new RUD chain grades offer optimal wear resistance.  
**More on page 10**



**Are your chains or the teeth of the gears suddenly breaking? Is your system coming to a standstill due to this? How much is the damage if you have to shut down the system as a result of this?**  
The new chain grades offer up to 28 % improvement in breaking force. Your system will run safer and the risk of breaking will be minimised. **More on page 11**



**Are you experiencing difficulties when installing components?**  
Then try our installation-friendly innovations such as Duomount or 2win. **More on page 26 und 42**

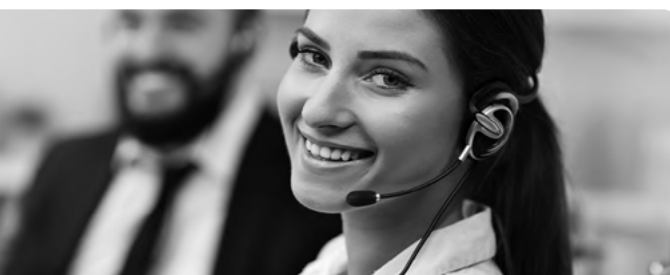

**Are you missing an on-site contact person?**  
Then contact our nearest branch.  
**More at [www.rud.com](http://www.rud.com) (units & locations)**



**Do you wish for more technical consultation and assistance?**  
Then simply ask us. directly contact our engineers and send us your challenges related to the conveyor system. **[conveyor@rud.com](mailto:conveyor@rud.com) // Technical questionnaires from page 64**

<b>RUD Service range and milestones</b> .....	04
<b>RUD milestones for conveyor systems</b> .....	06
<b>RUD conveyor chain systems</b>	
Conveyor systems for horizontal conveyance .....	08
Conveyor systems for vertical conveyance .....	09
<b>RUD chain technology</b> .....	10
<b>Round steel chain - hardness profile</b> .....	12
<b>Round link steel chains – RUD specifications at a glance</b> .....	14
<b>Chain connector</b> .....	16
<b>System sprocket wheels</b>	
<b>Sprocket wheels</b> .....	18
Our Tip: Tooth segments with increased pitch circle diameter .....	20
<b>Reversing wheels: Type A, B and C</b> .....	21
<b>Submerged overhung idler (SOI)</b> .....	22
<b>Attachment-System sprocket wheel</b>	
<b>Attachment</b> .....	24
<b>Scrapers</b> .....	28
<b>System pocket wheel</b>	
<b>Pocket wheel</b> .....	32
<b>Bucket attachments</b> .....	36
Description chain elevators .....	38
System RUca, 2win, SWA .....	40
<b>SYSTEM 65</b> .....	45
Reversing wheel .....	46
Sprocket wheel .....	47
<b>Central chain</b>	
<b>RU50, RU80, RU150 and RU200</b> .....	48
Drive wheel .....	51
Drive wheel, tension sprocket .....	51
<b>Belt type bucket elevator</b> .....	52
<b>Trough chain conveyor</b> .....	56
<b>FORKY forked chains</b>	
Single & double strand .....	58
Attachment, components, wheels, sprockets .....	59
Trough chain conveyor with forked chain FORKY .....	60
<b>Screw conveyor</b> .....	62
<b>General instructions for installation and operation</b> .....	64



## RUD SERVICE RANGE AND MILESTONES

### RUD CONVEYOR TECHNOLOGY IN THE POWER STATION

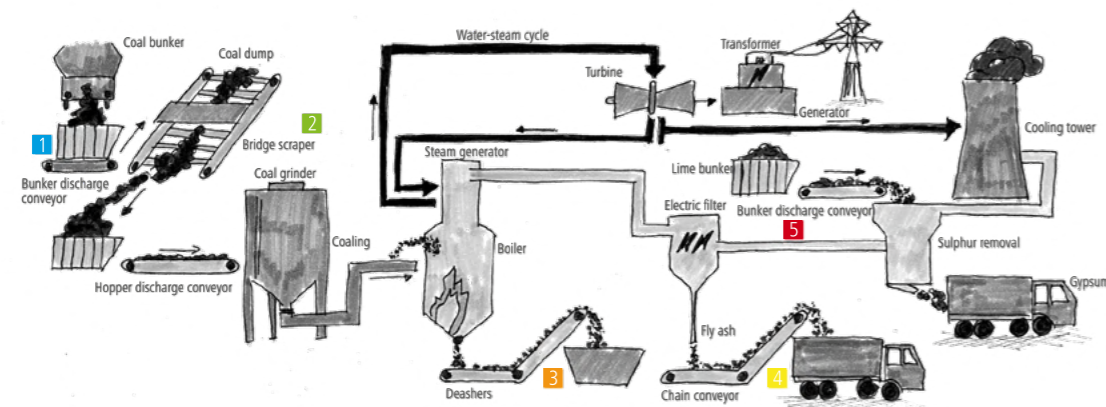

- 1 Bunker discharge conveyor
- 2 Bridge scraper
- 3 De-asher
- 4 Chain conveyor
- 5 Components

Fossil fuel power stations are an important contributor to the global energy supply. For decades, RUD has ensured the high availability of coaling and ash remove plants through conveyor chains. Due to our extensive experience in ash removal from large power plant boilers, biomass combustion, as well as waste incineration and recycling, all our system components are coordinated and work consistently and reliably.



- 1875 RUD as the foundation of ERLAU AG
- 1951 First RUD global case hardened round link steel chain
- 1957 First RUD chain for de-ashing
- 1965 First round link steel chain in RUD 40 cG material
- 1985 First round link steel chain with RUD super 35 quality
- 1992 First RUD apron conveyor
- 2006 Attachment DUOMOUNT
- 2007 RUD forked link chain FORKY
- 2008 First dry ash remover with RUD chains
- 2012 First bio gas substrate feeder
- 2015 Conveyor chain R160
- 2019 UKS chain connector

OUR REFERENCES IN THE POWER STATION  
AMONG OTHERS, WE ARE SYSTEM PARTNERS  
OF:





## MILESTONES FOR CONVEYOR SYSTEM FOR BULK MATERIALS

OVER 200 YEARS OF COMPTENCE

Whether it is a complete bucket conveyor, trough chain conveyor or spare parts for chain conveyors or maintenance and service, the RUD group is a reliable partner. Whether it be transporting limestone from the mill to the bulk tank or conveying salts from the mine to the surface, our conveyor systems are robust and are optimally designed for these conditions. Thanks to our extensive experience in bulk conveyance of fertilisers, potassium & salt, cement and other special bulk materials, all our system components always work reliably.

- 1875 Foundation of RUD Ketten Rieger & Dietz GmbH u. Co. KG
- 1906 As the first company, RUD introduces electric welding of chain links
- 1945 Foundation of business area of conveyor systems by Werner Rieger
- 1961 Introduction of double-pitch case-hardened round link steel chains for high-capacity bucket elevators
- 1965 Introduction of round link steel chain in 40cG material / market introduction of two-link bucket attachment system 65
- 1985 Round link steel chain with RUD super 35 quality
- 1992 RUD apron conveyor
- 1994 RUD central chain installed in high-capacity bucket elevators
- 2001 Market introduction of RUD SWA side-wall attachment
- 2004 Integration of H & E in RUD group
- 2006 Market introduction of RUD 2win two-link bucket attachment
- 2007 RUD forked link chain FORKY
- 2008 Central chain bucket elevator for 800 t / h
- 2009 First trough chain conveyor with RUD forked link chain FORKY
- 2011 1st tandem central chain bucket elevator for 1500 t / h
- 2011 Introduction of brand name BULKOS
- 2015 Conveyor chain R160
- 2017 Market introduction RUD RUca single-link attachment short assembly and disassembly times, without special tools

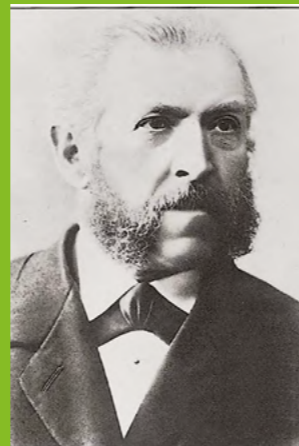
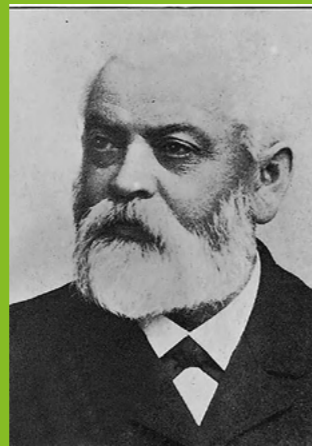











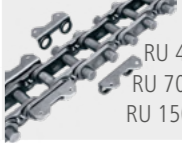



















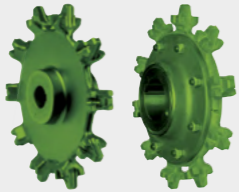

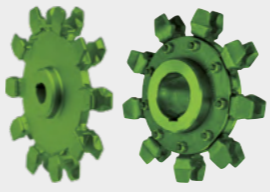





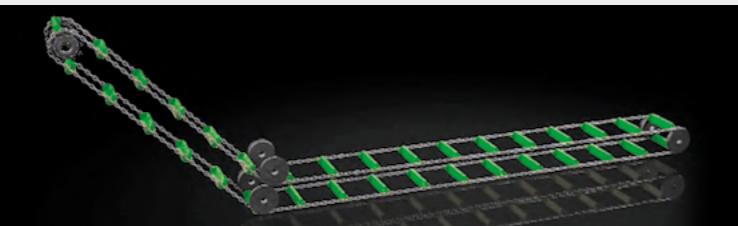
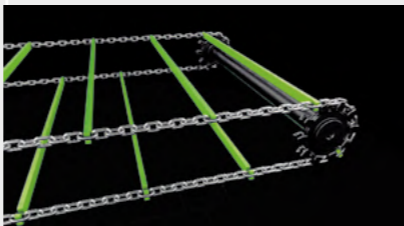

### MILESTONE OF H + E HERFURTH & ENGELKE CONVEYOR SYSTEM TECHNOLOGY Braunschweig / Germany

- 1932 Foundation of engineering office for conveyor systems
- 1933 Creation of 1st continuous flow conveyor for bulk materials
- 1940 Beginning of own production of 1st chain bucket elevator, 1st screw conveyor, 1st apron conveyor
- 1945 Foundation of machine factory Herfurth & Engelke
- 1960 1st belt bucket elevator
- 1969 1st chain bucket elevator for 300 t / h
- 1970 1st trough chain conveyor for 600 t / h
- 1972 Transport of 1000 t / h (band conveyor)
- 1973 1st screw conveyor for 300 t / h
- 1981 1st vertical screw conveyor
- 1985 Development of high-capacity bucket elevator, 1st usage of steel cord belt in bucket elevators
- 1988 Development of parallel weight tensioning station for bucket elevators, transport of 3000 t / h (band conveyor)
- 1998 1st central chain bucket elevator, 1st chain bucket elevator for 1100 t / h
- 2001 1st central chain bucket elevator for 600 t / h
- 2025 Merger with RUD System - now RUD H&E GmbH

# OUR RUD CONVEYOR CHAIN SYSTEMS

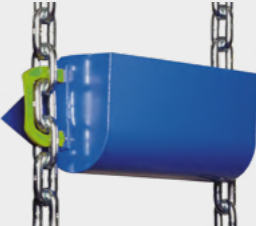
## AT A GLANCE

	HORIZONTAL CONVEYOR						VERTICAL CONVEYOR							
RUD-System	Sprocket wheel system			System pocket wheel			System 65	2win System / RUca	SWA System	Central chain system				
Chain	 Size 8 × 31 ... 38 × 144, Grade R80, R100, R140, R160						 Size 14 × 50 ... 34 × 126, F R80, R100, (R140)				 RU 40, RU 55, RU 70, RU 100, RU 150, RU 200			
Connectors	 FL 38 × 144, 26x92, 30x108, 34x126	 RSP 8 × 31 ... 10x38, 14 × 64	 VK 19 × 120	 UKS 14 × 50 ... 34 × 136			 UKS 14 × 50 ... 34 × 136	 FL 38 × 144	Coupling strand; rarely necessary, if the tensioning distance is long enough					
Attachment type	Multiple link attachment		Single link attachment		Single link attachment		Multiple link mounting			Mounting angle				
Attachment	 Duomount 26 × 100...	 SSRF 14 × 50... 38 × 144	 SSR 10 × 38... 30 × 120	 F 18 × 64... 22 × 86	 MEZZ 10 × 31 ... 38 × 144	 FM 8 × 31... 30 × 120	 MEET (K) 10 × 38... 38 × 144	 F 18 × 64... 22 × 86	 MEZT 10 × 38... 30 × 120	 System 65 14 × 50 ... 34 × 136	 2win 14 × 50 ...34 × 136	 RUca 26 × 100	 SWA 16 × 64 ...30 × 120	 is a separate part of the chain
Drive wheels	 Drive sprocket (internal) interlocked.		 Above size 14 × 50 mostly multi-part, locks always run vertically across the gears		 Drive pocket wheels (external) interlocked, mostly multi-part at the drive, rarely single, locks always run vertically as well as horizontally across the gears; preferred installation type vertical. Reversing wheels – very often also pocket wheels, rarely pulley blocks of type B for attachment F and type C for MEET(K) or MEZT.		 Driving wheel toothed with individual teeth	 Driving wheel not toothed, hardened segments, toothed drive such as in system 65 even in difficult applications	 Drive wheel toothed with individual teeth, rarely not toothed	 Drive not toothed, hardened				
Reversing wheels	 Type A with rim often at the tensioning station and as SOI, type B without rim for all the remaining deflections, rarely single gear wheels.		 Type C for attachment mezz and FI, alternative is single gear wheels.				 Reversing section always used with smooth sprocket, unhardened segments and flanged wheel	 Reversing section always used with grooved sprocket, unhardened segments, special cases and with flanged wheel	 Reversing section always used with grooved sprocket, unhardened segments and constriction wheel with hardened segments	 Reversing section toothed (from 800 bucket width) / without teeth (up to 710 bucket width), hardened				
Applications														
Comments	<p>The sprocket wheel system is advantageous for conveyors that have an angled line profile (several times) (reversing wheels help this type of conveyors in association with the attachment) and have a sharp increase (&gt;20°). Scraper height depending on the chain width, material to be transported and the gradient of the conveyor as well as the conveyance capacity must be calculated. Usual conveyance speed of 0.02 m/s to approximately 0.15 m/s depending on the service life to be projected. Typical example: de-ashing systems in power stations.</p>			<p>Universally applicable as cleaning scraper conveyor, bunker discharge conveyor (multi-belt conveyor) as well as apron conveyor. Usual speed of 0.05 m/s to 0.2 m/s depending on the material to be transported. Straight line profile preferred, slightly inclined (up to 20°) installations possible. Scraper height normally not greater than <math>0H = 1.5 \times ba</math>.</p>			<p>System 65 for sticky, coarse-grained bulk materials, when using high-capacity bucket conveyors and speed 1.35 ... 1.5 m/s.</p>	<p>2win-System for DIN bucket elevators (DIN bucket without gear teeth, hl and special bucket toothed), low granulation (up to 40 mm without gear teeth, toothed after that), speed of 1.0 ... 1.4 m/s;</p>	<p>SWA System for small conveyance capacities and low speed (...0.8 m/s), highly abrasive materials to be transported that are difficult to empty (central discharge with technical consultation).</p>	<p>Central chain bucket elevators for large conveyance capacities, coarse dry bulk materials (clinker, gravel, circulating goods and cement granules) and high speed (up to 1.7 m/s); steel chain bucket elevators.</p>				

# RUD CHAIN TECHNOLOGY

## SPECIAL PRODUCTS – WHAT HAS IMPROVED IN OUR NEW CHAIN GRADES?

**1** 100% CONSISTENTLY INDUCTIVELY HEATED RODS



This results in: Accurate link geometry · Highly calibrated links  
Customer benefit: · Optimised running geometry with components and wheels · Better interlink contact to extend chain life

**2** 100% FULLY AUTOMATIC WELDING CONTROLLER WITH PRECISE LINK



This results in: Optimal process control  
Customer benefit: Longer life · Increased breaking force · Safer operation

RUD is a benchmark company in providing quality products with advantages in wear resistance and performance ahead of all competing companies

**3** 100% FULLY AUTOMATIC CONTROL AND REGULATION OF CALIBRATION

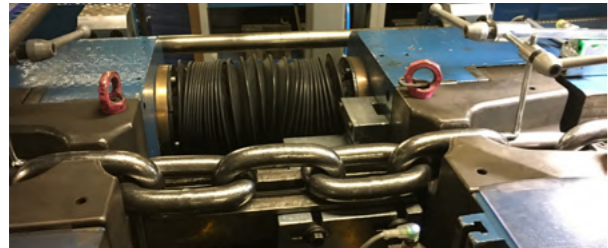

This results in: Highly calibrated chain strands · More accurate chain properties for multi-strand applications  
Customer benefit: Optimised run-in behaviour · Lower wear · Lower maintenance costs

**4** 100% WORLD FIRST! RUD CONVEYOR CHAIN R160 MADE OF SPECIALLY SMELTED SPECIAL STEEL



This results in: New options in heat treatment  
Customer benefit: Improved wear characteristics in case of equal breaking force

## BENEFIT FROM OUR HIGH PERFORMANCE

Performance		RUD Special grades				
Property	RUD	R80	R100	R140	R160	
Wear	Carburising depths in the link after macro etching (HTÄ) (... x d)	0,10	0,10	0,14	≥0,16	
	Surface hardness in the link (HV)	800	800 - 820	≥820	≥820	
	System components (compatible with each other)	+++	+++	+++	+++	
Operational safety	100% calibrated / reproducibility	+++	+++	+++	+++	
	Special fused metal for chain steel with special alloy proportions	+	++	++	+++	
	Crack retention capacity	+	+++	+++	+++	
Simple assembly / Traceability	Matching	+++	+++	+++	+++	
	Labelling on every component and chain link	+++	+++	+++	+++	
	Labelling of suitable pair using colours	+++	+++	+++	+++	
Downsizing	Tensile stress up to (N/mm²)	340	450	400	400	

## RUD ROUND LINK STEEL CHAINS

RUD SPECIFICATIONS, HARDNESS CURVES

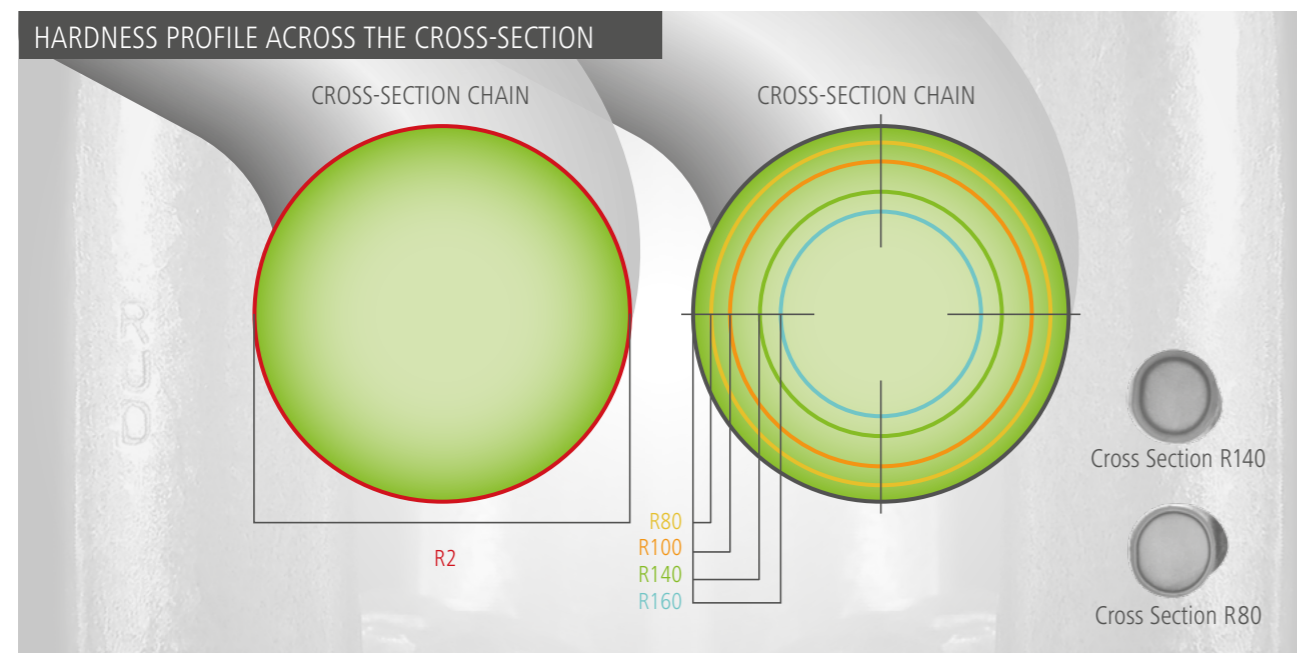
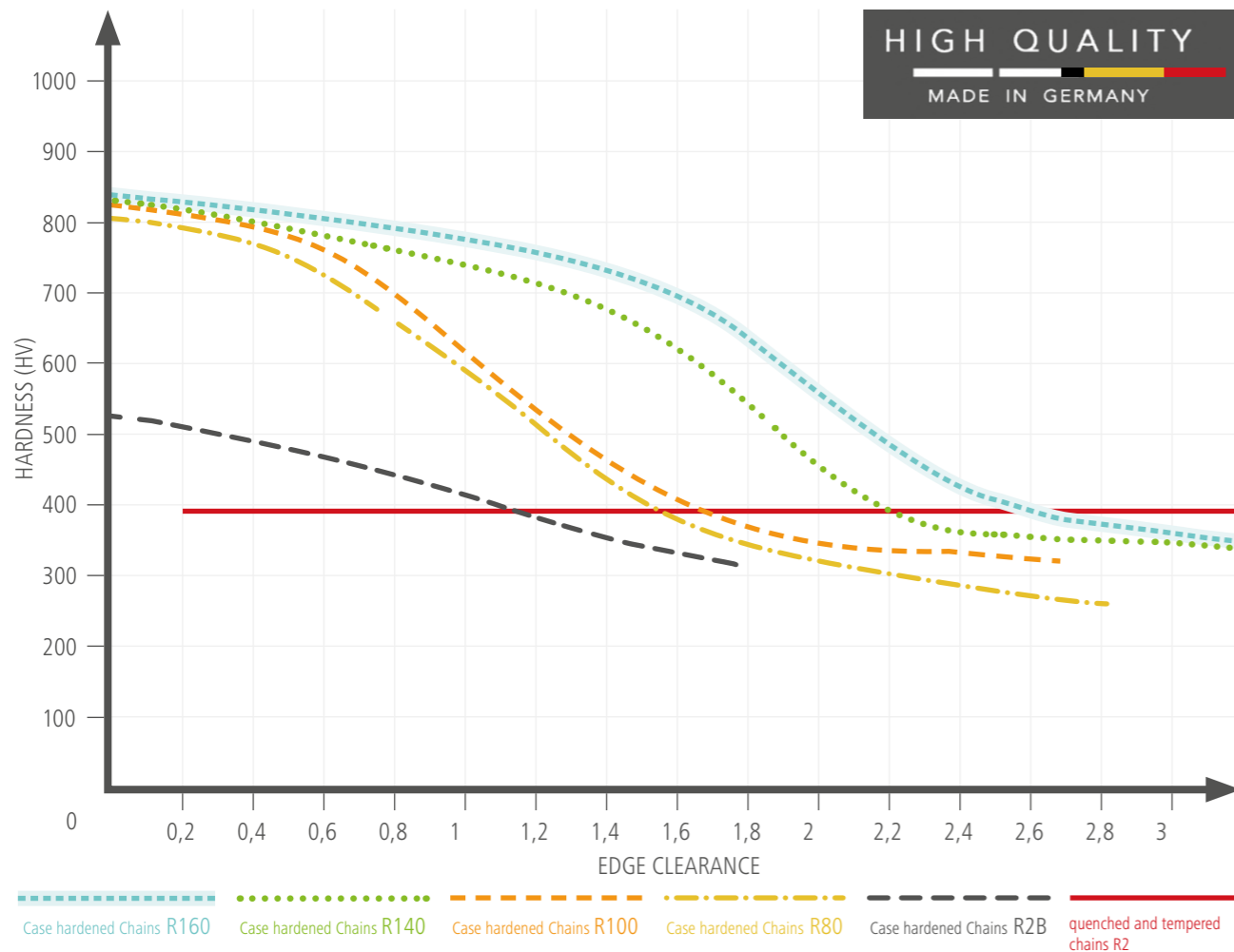

## RUD ROUND STEEL CHAIN R160

TOUGH AND 30% MORE RUNNING TIME

RUD offers its customers nothing less than double the service life in the use of bucket elevators and ash removal systems – the new round steel chain R160 has been optimised for a longer service life.

Our special chain steel improves the wear behaviour significantly without any loss of breaking force. Its breaking stress of up to 400 N/mm<sup>2</sup> provides especially for particularly rough and heavy duty operating conditions (e.g. in coal fired powerplants) a better performance in relation to other chain grades and therefore an increase of the revision time frame up to two times. The operating time of the whole facility will be significantly increased.

The R160 is currently available in the following sizes:

- 22 x 86 mm
- 26 x 100 mm
- 30 x 120 mm
- 34 x 136 mm
- 38 x 144 mm

The RUD R160 offers improved technical features that contribute to higher economic efficiency and operational safety. In combination with other products in the portfolio, RUD offers its customers the most innovative tailor-made solutions.

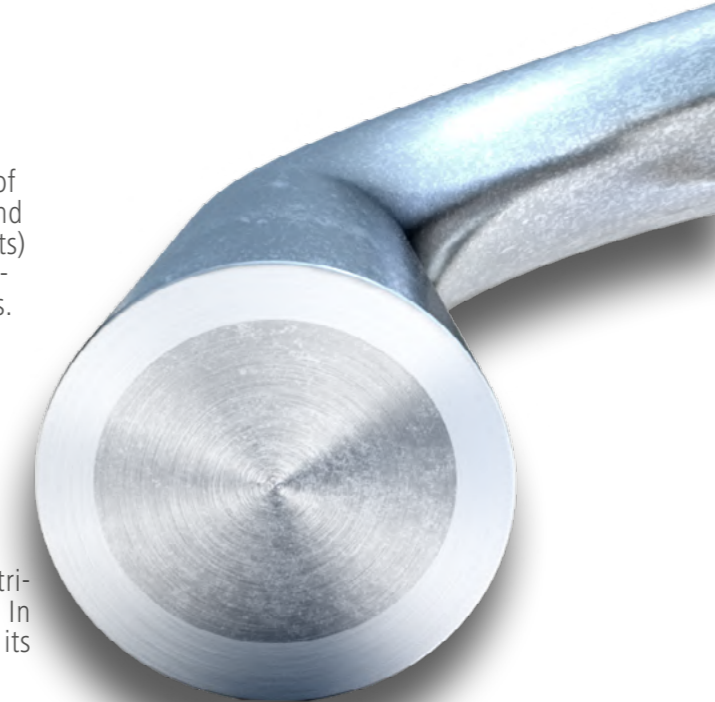

MORE THAN YOU EXPECT - FULL OPERATION IN ROUGH CONDITIONS



RUD stands for innovation and quality. With the R160, RUD's think tank launched a product on the market that can clearly extend the service life of our bucket elevator. The R160 acquisition costs were certainly higher, but considering the TCO (Total Cost of Ownership), the investment has definitely been worth it. All plant owners will certainly be keen to increase their production capacity levels while reducing costs at the same time. This goal can indeed be achieved with the R160."

Robert Ott  
Head of Maintenance

**LafargeHolcim**  
www.lafargeholcim.com

# RUD ROUND STEEL CHAIN

## RUD SPECIFICATION

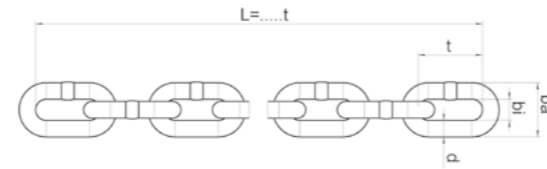

### Properties

- Highly wear-resistant for a long time
- Self-cleaning
- Simple assembly and disassembly of RUD components in the chain belt

- High-strength, as optimally heat-treated
- Low-maintenance when compared to other systems

ROUND STEEL LINK CHAINS IN SPECIAL GRADES – HIGHLY WEAR-RESISTANT						ROUND STEEL LINK CHAINS IN SPECIAL GRADES – HIGHLY WEAR-RESISTANT <sup>*3)</sup>																					
Chain d x t in [mm]	Chain width		Weight [kg / m]	Strand length (m / link) <sup>*1)</sup>	Attachment distance [Links]	R2		R2B		R80		R100		R140		R160		Chain d x t in [mm]									
	bi (min.) [mm]	ba (max.) [mm]				Breaking Force [kN]	RUD Part number	Breaking Force [kN]	RUD Part number	Breaking Force [kN]	RUD Part number	Breaking Force [kN]	RUD Part number	Breaking Force [kN]	RUD Part number	Breaking Force [kN]	RUD Part number		Breaking Force [kN]	RUD Part number							
8 x 31	10,3	28	1,3	<b>50,0/1613</b>	variable	80	51697											8 x 31									
				Fitting strand															7983021	50	7905630	7905631					
10 x 38	12,5	34	2,1	<b>50,0/1315</b>	variable	125	7987062											10 x 38									
				Fitting strand															7983022	75	7905633	7905634					
14 x 50	16,3	47	4,0	<b>20,026/527</b>	variable	250	8504309 <sup>*2)</sup>											14 x 50									
				Fitting strand																140	7905636	7905638					
14 x 64	16,3	47	3,7	<b>19,95/399</b>	variable													14 x 64									
				Fitting strand																128 <sup>*4)</sup>	7900548	7982305					
16 x 64	20	55	5,1	<b>10,176/159</b>	variable			240	7988920									16 x 64									
				Fitting strand																180	7905640	7905641					
18 x 64	21	60	6,9	<b>19,9/311</b>	variable													18 x 64									
				Fitting strand																225	7905643	7905644					
19 x 75	22	63	7,7	<b>15,296/239</b>	variable				340	7904795								19 x 75									
				Fitting strand																260	7905646	7905648	230	7905862	7905863	230	7909280
19 x 120	23	65	6,3	<b>10,725/143</b>	2													19 x 120									
				Fitting strand																260	7905650	7905651	7905652				
22 x 86 <sup>*5)</sup>	26	74 (73)	9,7 (9,5)	<b>3,0/25</b>	variable	610	8504310 <sup>*2)</sup>	450	7101775	260	7905474							22 x 86 <sup>*5)</sup>									
				Fitting strand																350	7905654	7905655	310	7905719	7905720		
25 x 95	34	90	12,5	<b>5,16/43</b>	4													25 x 95									
				Fitting strand																400	7905657	7905658					
26 x 92	30	85	13,7	<b>10,234/119</b>	variable													26 x 92									
				Fitting strand																850	7906999 <sup>*2)</sup>	370	7905480	7905477	7905491	7905660	7905722
26 x 100	31	87	13,3	<b>8,265/87</b>	4/8/10/16													26 x 100									
				Fitting strand	nx4 + 1x6														370	7905492	430	7905661	370	7909277	430	7905723	
					4/6/12/14															7905493		7905662		7909278		7905724	
					–															7905497		7905662		7909278		7905724	
30 x 108	34	97	18,0	<b>8,3/83</b>	variable													30 x 108									
				Fitting strand																1130	7907002 <sup>*2)</sup>	470	7905496				
30 x 120	36	102	17,5	<b>10,692/99</b>	4/6/8/12/16													30 x 120									
				Fitting strand	10														470	7905498	640	7905664			580	7905727	
					–															7905499		7905666				7905728	
34 x 126	38	109	22,7	<b>5,640/47</b>	variable													34 x 126									
				Fitting strand																1450	7907005 <sup>*2)</sup>	615	7905502	720	7905670		
34 x 136	39	113	23,8	<b>8,694/69</b>	4/6/12/18													34 x 136									
				Fitting strand	8/12															7905521		7905675		7905865		7908694	
					4/6/10															7905522	720	7905676	630	7905866	670	7908692	
38 x 144	44	127	30,0	<b>3,312/23</b>	–													38 x 144									
				Fitting strand															–		7905506		7905678		7905868		7908695
																			–				7905680		7905681	850	7908697

\*1) Maximal variable length: no longer than the standard belt length (in bold print)  
 \*2) Length in compliance with ordering specifications  
 \*3) Allowed tolerance of breaking tension +/- 10%

\*4) RUD materials R40c-G/s3  
 \*5) Bracketed values for chain material R2

# RUD CHAIN CONNECTORS

## UKS // CONNECTING LINK

### UNIVERSAL CHAIN CONNECTOR UKS

Advantages of the UKS chain lock

- Quick and easy installation by one person
- Case hardening corresponds to the qualities R80-R160
- Fits RUD pocket and chain wheels
- Improved design of the teeth to prevent breakage
- It is no longer necessary to observe a tightening torque
- One connector for all transport tasks with round steel chains/link chains in conveyor technology. This means less stockholding & fewer order numbers in purchasing
- Easier and faster installation. This means less downtime for installation and repair of all types of conveyors
- No binding installation direction, as the UKS universal chain lock runs over pocket and chain wheels
- Reduces your total cost of ownership

RUD PART NO.	Chain d × t in mm	replaces VK	replaces RSP	replaces FL	A	B	kg / piece
7909021	14x50	54970	53900		48	14	0,26
7909532	16x64 / 18x64	61326	57947 / 52694		57	17	0,46
7910081	19x75	55021	55196		64	20	0,71
7909997	22x86	55035		55578	74	23	1,09
7909993	26x100	51487		62113	87	27	1,78
7909989	30x120	60551		53280	102	31	2,80
7909729	34x136	7991616		55357	113	35	3,99

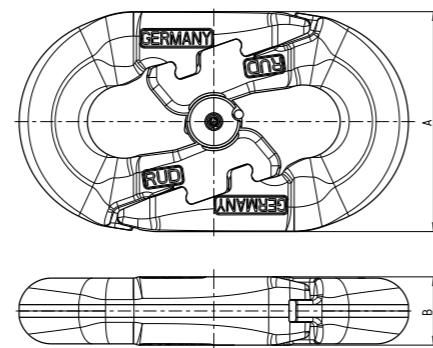

### CONNECTING LINK FOR CHAIN GRADE R2

Runs preferably vertical over pocket wheels

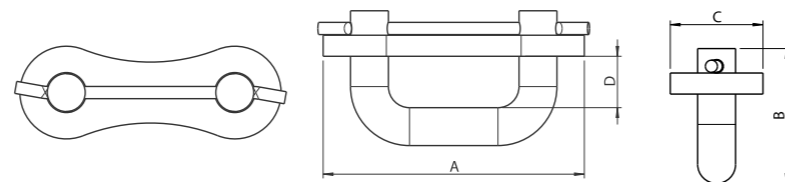

RUD Part no.	Breaking force (kN)	For chain d × t in mm	A	B	C	D	Weight (kg)
7986777	80	8 × 31	62	32	22	12	0,08
58594	125	10 × 38	77	36	28	13	0,14
7987640/8500097	246	14 × 50	96	46	32	17	0,8/0,9

# RUD CHAIN CONNECTORS

## RSP // VK // FL

### CHAIN CONNECTOR RSP (SPACE-SAVING)

#### Properties

- For using in single and multi-strand conveyors
- Highly wear-resistant
- Run over sprocket wheels, grooved wheels and flat wheels - vertical
- Run over pocket wheels vertical; In special cases horizontal run possible – see picture underneath
- For medium operating conditions

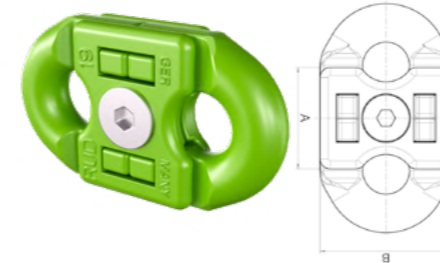

RUD Part no.	chain d × t in mm	A	B	C	E	kg / piece
58571*	8 × 31	22	29	10	M5	0,05
54959*	10 × 38	27	35	12	M6	0,1

\* Zinc-coated

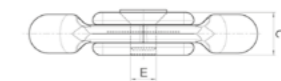

### CHAIN CONNECTOR VK

#### Properties

- For using in single and multi-strand conveyors, extremely robust and high wear volume
- Run only over sprocket wheels and flat wheels
- For difficult operating conditions

RUD Part no.	For chain d × t in mm	A	B	C	F	kg / piece
50039	19 × 120	61	70	67	M20	2,3

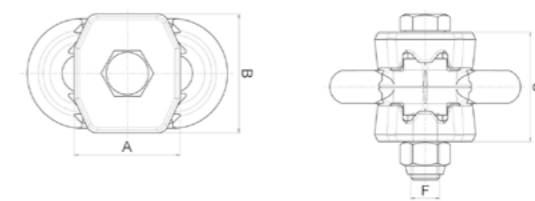

### FLAT CONNECTOR FL

#### Properties

- For using in single and multi-strand conveyors
- Highly wear-resistant
- Run over sprocket wheels and pocket wheels, grooved wheels and flat wheels
- Installation dimension corresponding to approximate chain link dimension
- Simple hammer assembly
- For medium to difficult operating conditions



RUD Part no.	chain d × t in mm	A	B	C	kg / piece
7990647	38 × 144	95	113	45	5,8



### MINING CONNECTOR

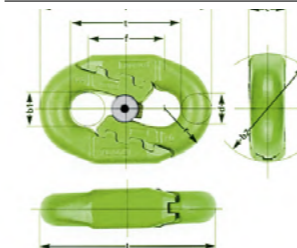

chain d × t in mm	b1	b2	c	f	l	r	Breaking-load kN*	Breaking strength N/mm <sup>2</sup> *	Cycles**
26 x 92	28	95	33	62	146	40	900	850	90.000
30 x 108	32	109	36	70	170	47	1200	850	150.000
34 x 126	36	120	40	76	196	52	1540	580	150.000

# RUD SPROCKET WHEELS

## MULTI-PART // SINGLE-PART

### SPROCKET WHEEL MULTI-PART\*

**Properties:**

- With replaceable, highly-wear-resistant tooth discs
- For difficult operating conditions



chain d × t in mm	No. of teeth	TK Ø	A	B	Standard Dimension C	E <sub>max.</sub>	F <sub>max.</sub> = Hole Ø in mm	Complete wheel approximately kg / piece
10 × 38	8	194	31	95	27,0	80	60	6,3
	12	291	31	140	27,0	80	80	15,5
	16	388	31	130	30,0	85	80	25,5
14 × 50	6	193	42	95	9,0	70	75	7,5
	8	256	42	120	25,0	75	85	11,6
	9	288	42	140	45,0	90	100	13,1
	10	319	42	160	45,0	90	100	20,6
	12	383	42	155	50,0	100	100	33,0
14 × 64	7	287	42	140	45,0	90	100	16,0
	8	328	42	160	45,0	90	100	21,5
	8	328	50	160	45,0	90	100	23,5
16 × 64	9	368	50	185	45,0	135	120	41,5
	10	409	50	200	45,0	120	135	49,5
	8	384	55	185	40,0	135	125	41,5
19 × 75	10	479	55	220	45,0	120	140	71,5
	8	440	55	185	40,0	135	120	76,5
22 × 86	9	495	65	230	80,0	160	140	88,5
	10	549	65	270	80,0	160	170	95,5
	8	512	78	270	100,0	200	180	110,0
26 × 100	9	575	78	300	45,0	170	220	141,0
	10	639	78	340	80,0	160	210	155,0

\* With tooth disc

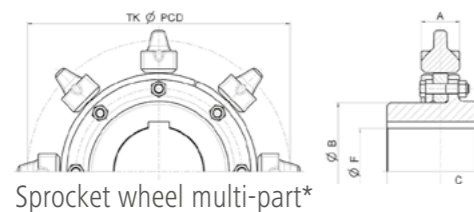

### SPROCKET WHEEL MULTI-PART\*\*

chain d × t in mm	No. of teeth	TK Ø	A	B	Standard Dimension C	E <sub>max.</sub>	F <sub>max.</sub> = Hole Ø in mm	Complete wheel approximately kg / piece
30 × 120**	8	614	98	320	90,0	180	220	140,0
	9	690	98	320	90,0	180	230	170,0
	10	766	98	320	60,0	190	200	216,0
34 × 136**	8	697	107	320	110,0	220	200	195,0
	9	783	107	380	110,0	220	240	262,0
38 × 144**	8	738	108	365	110,0	220	220	270,0

\*\* With replaceable, highly wear-resistant individual teeth

### SPROCKET WHEEL SINGLE-PART

**Properties:**

- Highly wear-resistant for difficult operating conditions
- Unhardened for easy operating conditions

chain d × t in mm	No. of teeth	TK Ø	A	B	Standard Dimension C	E <sub>max.</sub>	F <sub>max.</sub> = hole Ø in mm	Complete wheel approximately kg / piece
8 × 31	5	100	25	52	25,0	60	40	1,0
	7	139	25	92	27,5	55	65	2,6
	8	159	25	80	30,0	60	50	3,0
	10	198	25	95	17,0	47	65	3,6
	14	277	25	110	27,0	80	70	7,5
	16	316	25	120	27,0	80	80	9,2
10 × 38	22	434	25	120	45,0	90	80	16,1
	6	147	31	89	30,0	60	60	4,0
	7	170	31	114	25,0	75	85	3,3
	8	194	31	95	25,0	75	55	6,3
	10	243	31	90	20,0	60	50	6,5
14 × 50	12	291	31	140	27,0	80	90	15,5
	16	388	31	130	30,0	85	80	28,5
	6	193	42	92	40,0	80	50	7,5
	8	256	42	120	30,0	90	100	13,7
16 × 64	10	319	42	160	45,0	90	110	20,0
	16	510	42	160	60,0	120	100	31,5
	6	246	50	160	25,0	68	115	8,5
18 × 64	8	327	50	145	45,0	90	100	18,0
	9	368	50	160	30,0	125	110	26,5
	10	409	50	175	45,0	120	110	34,5
19 × 75	6	247	55	150	28,0	75	100	9,5
	8	384	55	180	40,0	135	110	40,5
22 × 86	9	575	78	220	45,0	120	120	85,0
	6	331	65	190	35,0	200	140,0	64,0

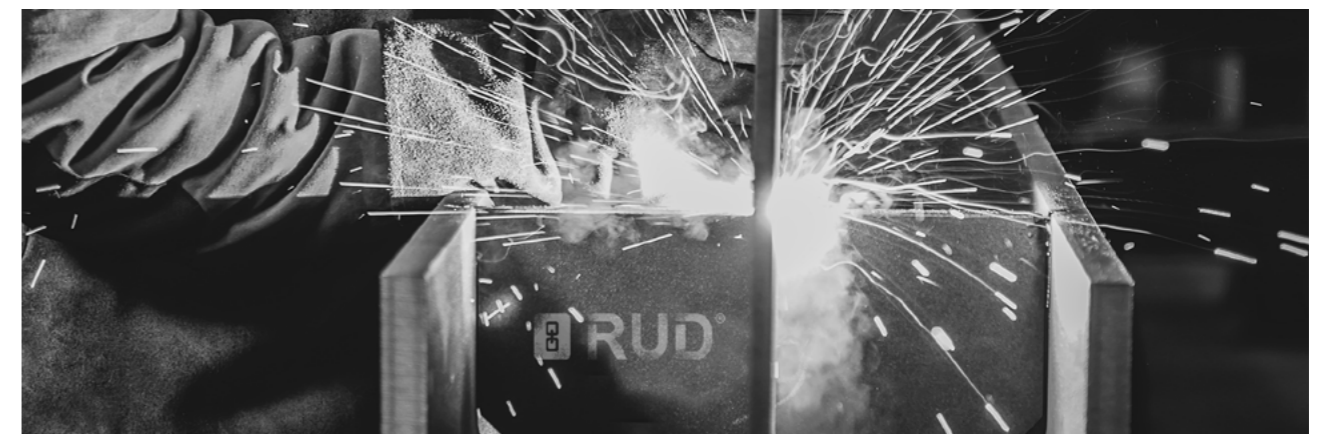
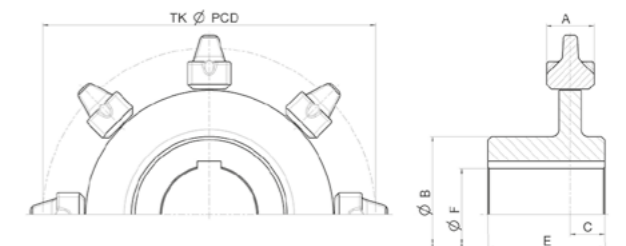

## OUR TIP

### TOOTHED SEGMENTS WITH INCREASED PITCH CIRCLE DIAMETER

Tooth discs and individual teeth, optimally adapted to the proportional chain extension given at the time of replacement. Available in dimensions 14x50 to 38x144 for all multi-part sprocket wheels. Prices on request!

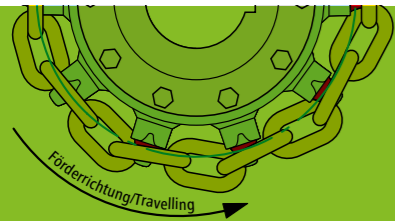

#### PREVIOUS – CHAIN RUNS AGROUND!

Indications of too heavily worked chain:

- Uneven run
- Hook formation at rear tooth flank
- Flank clearance used up
- Strong vibration at the drive
- Chain falls only after several teeth on chain link support of the teeth

P.C.D. of standard sprocket wheel

The chain suited enlarged p.c.d. of the teeth

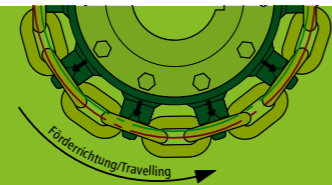

#### LATER – THE CHAIN WEAR IS COMPENSATED FOR BY USING A NEW TOOTH SEGMENT WITH LARGER TOOTH FLANK.

- The solution: sprocket wheels with increased pitch circle diameter.
- Replaceable tooth segments / individual teeth increase the life cycle of the complete sprocket wheel Run-in behaviour of worn chain at the driving gear

- A. Distance of horizontal chain link – horizontal link support at the tooth (approx. 30 – 35 mm)
- B. Synchronisation of vertical link at the outermost tip of the tooth

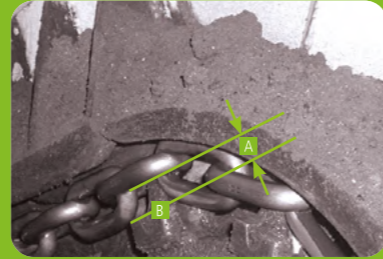

#### STRUCTURE OF SPROCKET WHEEL – MULTI-PART

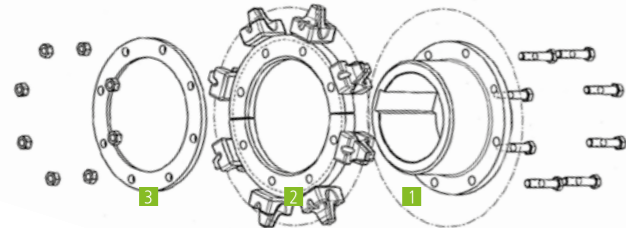

1. Hub disc
2. Tooth wheel segment
3. Counter disc

With new chain components, the horizontal link stays on the link support of the tooth. When chain elongation occurs due to wear and tear, the horizontal links do not sit on the support but rest on the sprocket tooth tip. This leads to both the horizontal and vertical links sitting on the sprocket tooth which can cause chain derailment and damage

**IN CASE OF NEW CHAINS, NEW TOOTH DISCS / INDIVIDUAL CHAINS SHOULD ALWAYS BE USED.**

**Tip:** By inserting new single teeth with enlarged pitch circle diameter, the chain wear is compensated and the service life will be extended

## RUD REVERSION WHEELS

### TYPE A // TYPE B // TYPE C



TYPE A

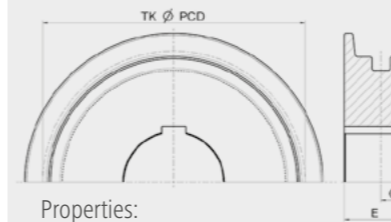

- Properties:
- Grooved wheels with rim
  - For using at tensioning stations

For chain d x t in mm	Corr. teeth number	TK Ø	C*	E* (Typ A or C)
10 x 38	8	194	15,5	45
	10	243	15,5	45
	12	291	15,5	45
14 x 50	8	256	21	60
	10	319	21	60
	12	383	21	60
16 x 64	8	327	25	70
	10	409	25	70
	12	490	25	70
18 x 64	8	323	27,5	80
	10	402	27,5	80
	12	482	27,5	80
19 x 75	8	384	27,5	80
	10	479	27,5	80
	12	574	27,5	80
22 x 86	8	440	32,5	90
	10	549	32,5	90
	12	658	32,5	90

Other sizes on request.



TYPE B



- Properties:
- Grooved wheels without rim
  - For using in loose side of the belt under the trough

For chain d x t in mm	Corr. teeth number	TK Ø	C*	E=2C* (only Typ B)
10 x 38	8	194	15,5	31
	10	243	15,5	31
	12	291	15,5	31
14 x 50	8	256	21	42
	10	319	21	42
	12	383	21	42
16 x 64	8	327	25	50
	10	409	25	50
	12	490	25	50
18 x 64	8	323	27,5	55
	10	402	27,5	55
	12	482	27,5	55
19 x 75	8	384	27,5	55
	10	479	27,5	55
	12	574	27,5	55
22 x 86	8	440	32,5	65
	10	549	32,5	65
	12	658	32,5	65

Other sizes on request.



TYPE C

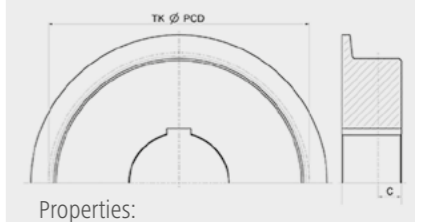

- Properties:
- Plain wheels with rim
  - For both the use cases, however only possible when using flange attachments and very short scraper distances

For chain d x t in mm	Corr. teeth number	TK Ø	C*	E* (Typ A or C)
10 x 38	8	194	15,5	45
	10	243	15,5	45
	12	291	15,5	45
14 x 50	8	256	21	60
	10	319	21	60
	12	383	21	60
16 x 64	8	327	25	70
	10	409	25	70
	12	490	25	70
18 x 64	8	323	27,5	80
	10	402	27,5	80
	12	482	27,5	80
19 x 75	8	384	27,5	80
	10	479	27,5	80
	12	574	27,5	80
22 x 86	8	440	32,5	90
	10	549	32,5	90
	12	658	32,5	90

Other sizes on request.

\* To order, please use the questionnaire on page 70 and / or pages 68/69.

# RUD SUBMERGED OVERHUNG IDLER

(SOI - SUBMERGED OVERHUNG IDLER)

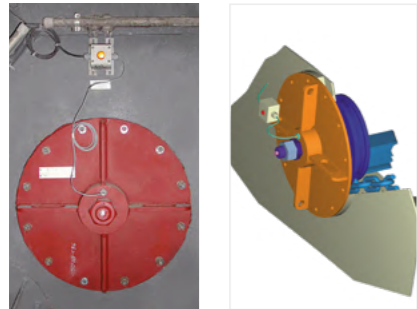

- Grooved wheels with rim for use in the hoistway
- Underwater sprockets vary from the normal reversion wheel only in the design of the "flying" shaft bearing, which are optimally designed by RUD for even these case studies. Numerous use cases all over the world prove their high availability.

## UNDERWATER SOI

- Ideal for wet de-ashing systems
- Electronic circulation control optionally possible
- Assembly of outer wall at the trough
- Suitable for modifying old systems
- High-quality, robust and easy-running bearing technology
- Optimised bearing seal
- Easily accessible for maintenance works
- Deliverable in all reversing wheel dimensions
- Two design versions: with or without bearing shield in-fixed casing hub

1. SOI REVERSION WHEEL
2. TROUGH WALL
3. CHAIN
4. BEARING SIGN
5. TROUGH BOTTOM
6. SCRAPER

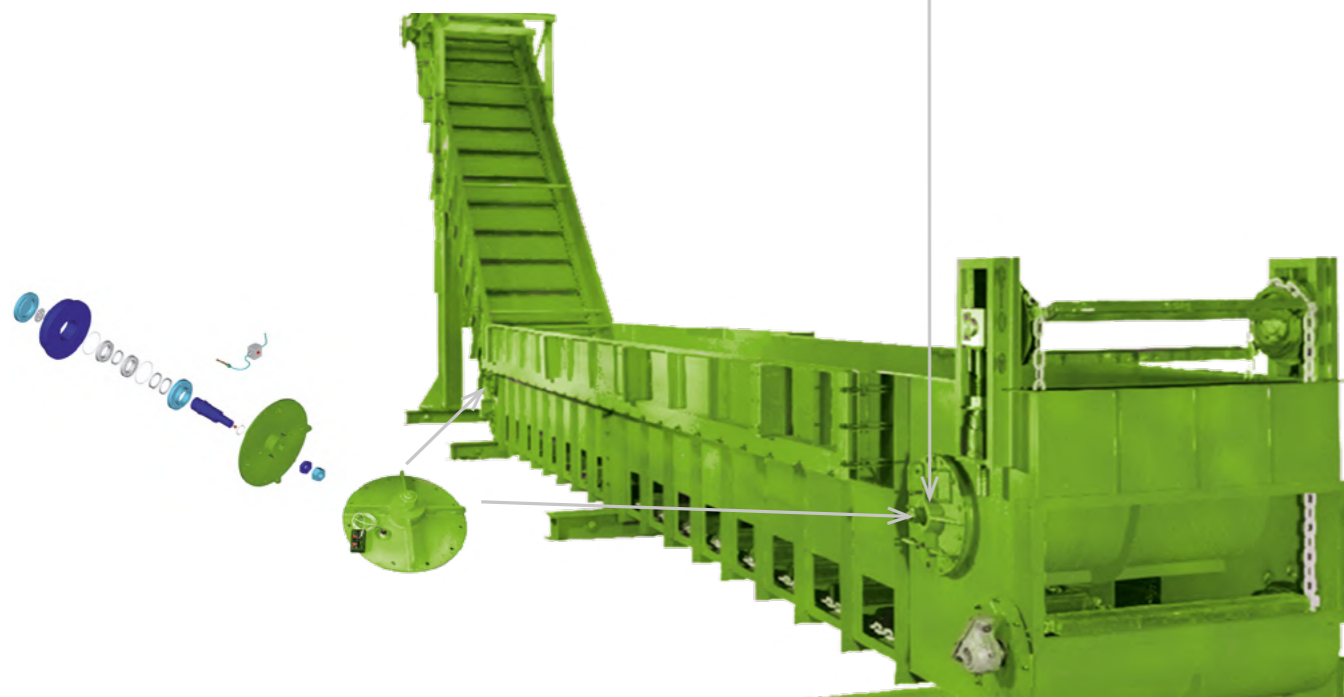
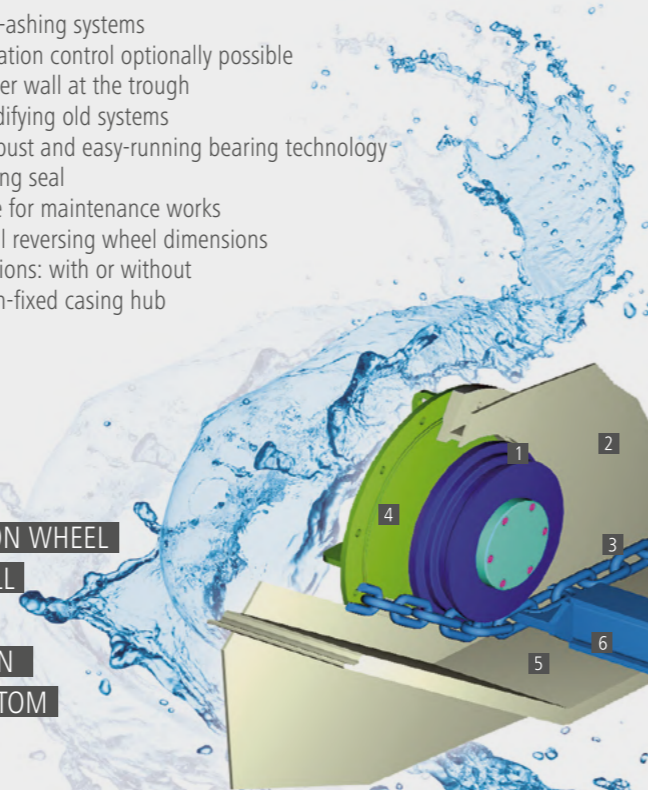

## DESIGN SOI 1

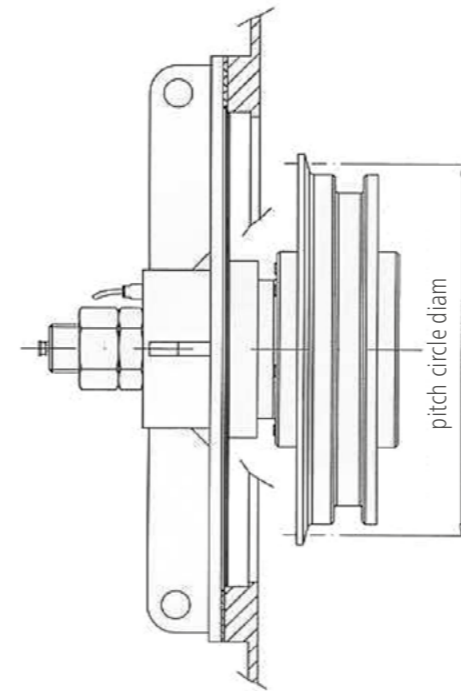

For chain d × t in mm	PCD Ø	Corresponding to the number of teeth
19 × 75	290	6
	384	8
22 × 86	331	6
	440	8
	549	10
26 × 100	386	6
	512	8
	639	10
30 × 120	426	6
	614	8
	766	10

## DESIGN SOI 2

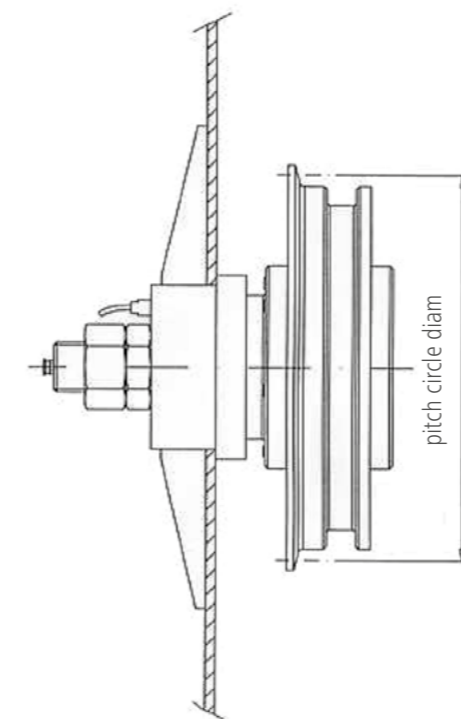

For chain d × t in mm	PCD Ø	Corresponding to the number of teeth
19 × 75	290	6
	384	8
	479	10
22 × 86	331	6
	440	8
	549	10

For ordering, please use the questionnaire on page 68 / 69. Other designs and sizes available on request.

# RUD ATTACHMENT SYSTEM SPROCKET WHEEL

## ATTACHMENT FM



- Properties:
- Screwed and can be clamped / screwed in the tensioned chain strand
  - For scraper height up to 1.8 times the outer chain link width
  - Variable scraper distance possible
  - For rough operating conditions
  - Run over sprocket wheels and plain wheels



RUD Part No..	For chain d × t in mm	A	B	C	E	F	G	H	I	kg / piece
52744	14 × 50	39	47	24,5	3	15,5	M12	65	10	0,4
52745								70	15	0,4
52746								75	20	0,4
52747	16 × 64	51	57	28,5	4	20	M16	80	15	0,8
52748								90	25	0,8
52749								110	45	0,8
52751	19 × 75	61	70	33,5	5	22,5	M20	110	30	1,4
52752								120	40	1,4
52755								130	50	1,4
52756	22 × 86	70	79	38,5	5	26	M20	110	20	1,9
52757								120	30	1,9
52758								130	40	1,9
52759	26 × 100	80	93	43	6	30	M24	130	30	3,0
7989190								160	60	3,0
52760	30 × 120	100	105	52,5	7	37	M30	160	40	5,2

H = screw length  
I = clamp length

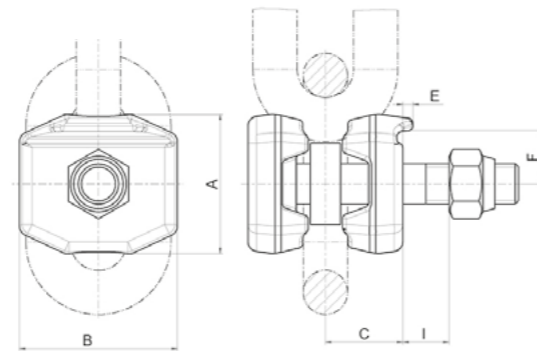

## MEZ-Z // F

### ATTACHMENT MEZ-Z

- Properties:
- For medium to difficult operating conditions
  - For scraper height up to 1.5 times the outer chain link width
  - Assembly and disassembly in case of tensioned chain possible
  - Run across sprocket wheels and flat wheels

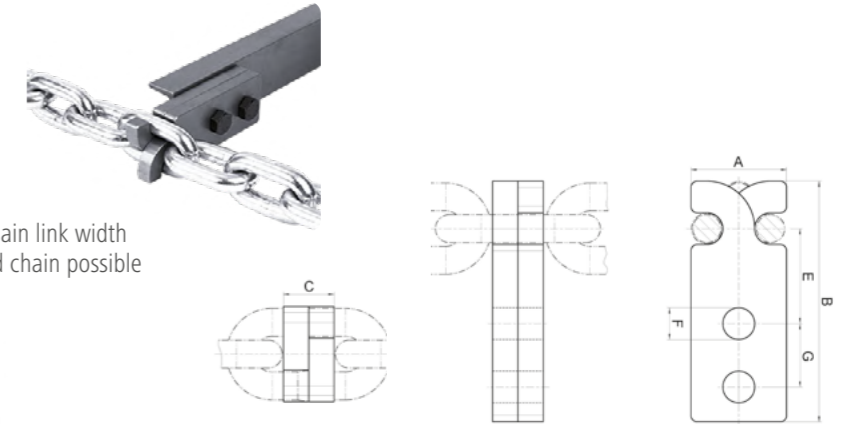

RUD Part No.	For chain d × t in mm	A	B	C	E	F	G	kg / pair
61629	10 × 38	35	100	12	37	11	30	0,3
61630	14 × 50	50	130	30	52	13,5	36	1,25
61635	22 × 86	75	190	36	75	22	50	3,2

### ATTACHMENT F

- Properties:
- For medium and difficult operating conditions
  - Directly welded
  - For scraper height up to 1.5 times the outer chain link width
  - Assembly and disassembly of scraper bars in case of tensioned chain loops
  - Replacement for chain ends and chain brackets
  - Run across sprocket wheels, pocket wheels and grooved wheels



RUD Part No.	For chain d × t in mm	A	B	C	E	F	G	K <sub>max</sub>	kg / pair
53215	18 × 64	126	35	30	65	17	40	45	0,64
55039	19 × 75	134	46	20	75	18	40	37	0,71
53065	22 × 86	139	46	20	80	18	40	51	0,71

Attachment F can also be used in pocket wheel system.

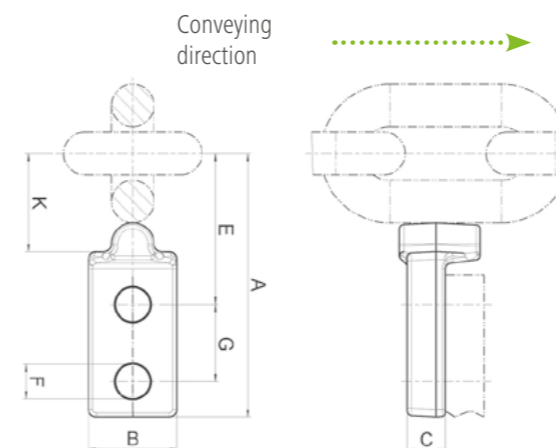

# RUD ATTACHMENT SYSTEM SPROCKET WHEEL

DUOMOUNT // SSR

## ATTACHMENT **DUOMOUNT**<sup>®</sup>

**Properties:**

- For very high conveyance capacities up to 50 t/h
- For scraper height up to 2.5 times the outer chain link width
- Scraper profiles of any shapes possible
- Highly wear-resistant
- Multiple link attachment
- Can be tensioned in the tensioned chain belt
- Variable scraper distance possible
- Runs over sprocket wheels and grooved wheels

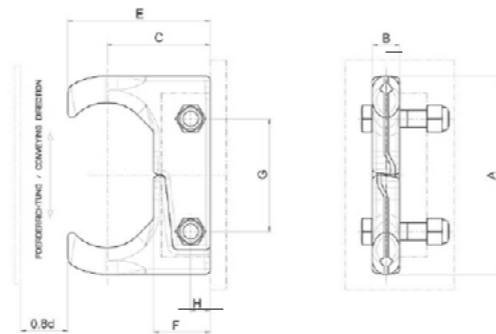

RUD Part no.	For chain d × t in mm	A	B	C	E	F	G	H	I	kg/ piece
7995852*	26 × 100	214	30	112	155	65	120	25	20,5	5,2

\* Distribution without screw!

## ATTACHMENT SELF-LOCKING – REVERSIBLE SSR

**Properties:**

- For difficult operating conditions
- For double-strand conveyors
- Reverse operation possible
- Robust and easy
- Run across sprocket wheels and grooved wheels

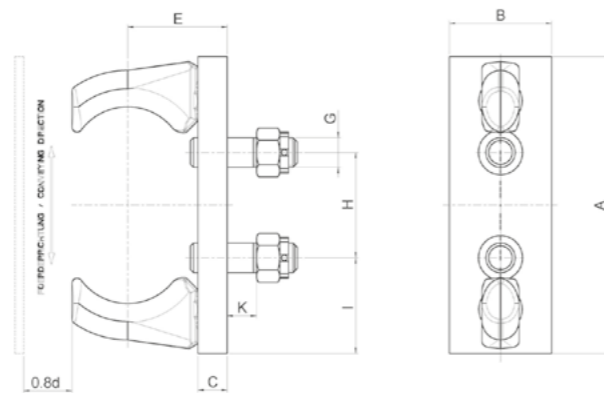

RUD Part no.	for chain d × t in mm	A	B	C	E	H	G	I	K	kg/ piece
55333	10 × 38	82	24	10	30	58	M 10	12	10	0,3
60812	19 × 75	175	60	20	58	65	M 20	62,5	20	2,5
60343	22 × 86	200	70	20	68	71	M 20	72,5	20	3,4
59991	26 × 100	235	80	20	72	85	M 20	75	20	4,8
62331	30 × 120	280	90	25	85	98	M 24	100	24	7,5

SSRF

## ATTACHMENT SELF-LOCKING – REVERSIBLE FLAT SSRF

**Properties:**

- For very high conveyance capacities
- For scraper height up to 2.5 times the outer chain link width
- Variable scraper distance possible
- Run over sprocket wheels and grooved wheels
- Multiple link attachment
- Weldable at scraper profiles of any shapes
- Highly wear-resistant

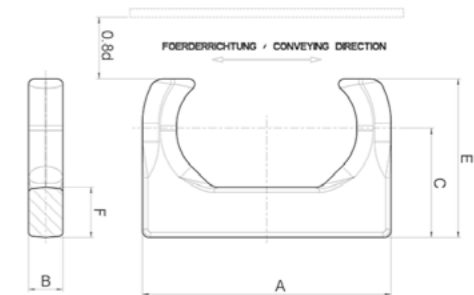

RUD Part no.	For chain d × t in mm	A	B	C	E	F	kg/ piece
7102723	14 × 50	110	16	50	73	25	0,5
7990392	16 × 64	135	19	59	83	30	0,8
63734	19 × 75	156	21	69	100	36	1,2
51297	22 × 86	182	25	80	116	37	2,0
63735	26 × 100	214	30	92	135	45	3,3
7102491	30 × 120	252	35	110	160	56	5,3
7102490	34 × 136	282	38	122	177	60	7,2
7992608	38 × 144	309	43	137	199	68	10,0



## RUD SCRAPER BARS

SAFER SCRAPER OPERATION WITH MATCHED RUD STRANDS

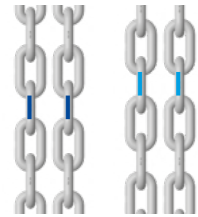

**RUD PRODUCT ADVANTAGE:  
LABELLING OF SUITABLE PAIR  
USING COLOURS!**

### OUR SCRAPER BARS AND ATTACHMENTS FORM THE PERFECT SYSTEM IN ASSOCIATION WITH OUR PAIRED CHAIN STRANDS:

- Simplest assembly and disassembly
- Optimal run across the pocket and sprocket wheels
- The suitable scraper design for every material to be transported

- Lower wear
- No scraper tilting
- Everything from a single source chains, connectors, scraper bars and wheels

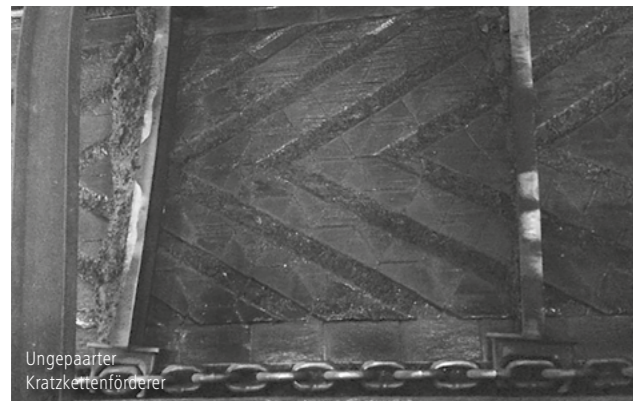

Strand lengths, production tolerance:  
+ 0.4 %  
- 0.15 % = 0,55 % max.  
i.e. for 10 m length, max. difference 55 mm

length tolerance  $\Delta X$  of matched chain left (Multiple-belt-conveyor)  
 $\Delta X = 0.05\%$  max., i. e. for e. g. 10 m long belts the max. difference is. 5.0 mm. if the length of the belt is < 8 m, the largest pair tolerance = 4 mm.

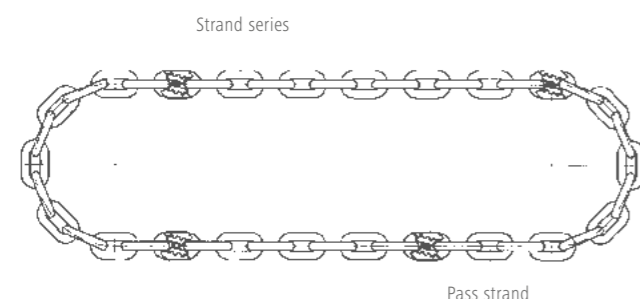
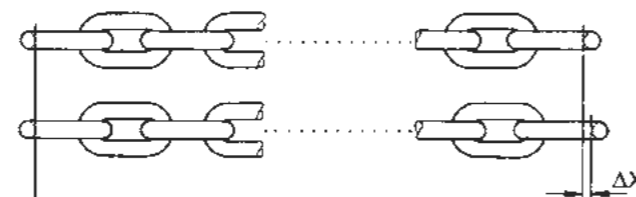

When ordering chain loops in millimetres, we require the precise scraper distance for distributing into individual chain strand lengths.

## RUD SCRAPER BARS

THE CORRECT SCRAPER BAR FOR YOUR REQUIREMENTS

RUD scraper bars are always optimally adapted to the requirements and operating conditions specified to us by the customer. We produce scraper bars as per the specifications of the customers, provided that no consultation or support is necessary. Alternatively, we suggest an optimal scraper version based on an intensive consultation, which is developed in the briefing.

The following information is hence necessary and evaluated by us:

- Clear trough width of the conveyor as well as its exact line profile
- Trough bottom material and design
- Chain centre distance

### USAGE EXAMPLES\* – SCRAPER BARS AND ATTACHMENTS

Standard U profile with MEE-T attachment

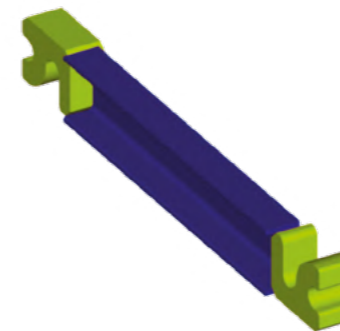

Typical usage options:  
Cleaning scraper conveyor

Standard scraper bar design for difficult conditions with SSRF or DUOMOUNT

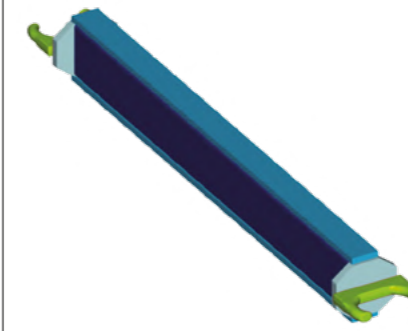

Typical usage options:  
Wet de-ashing systems

Standard angle profile with MEE-T attachment

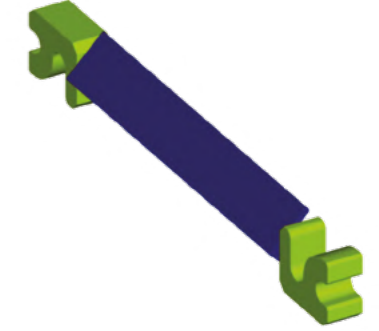

Typical usage options:  
Cooling systems / coal feeders  
Bunker discharge conveyor

\* Other scraper designs on request; if necessary, use the sketch on page 67



# RUD SCRAPER BARS

AREAS OF APPLICATIONS



DE-ASHER WITH SSRF ATTACHMENT



DE-ASHER WITH F ATTACHMENT

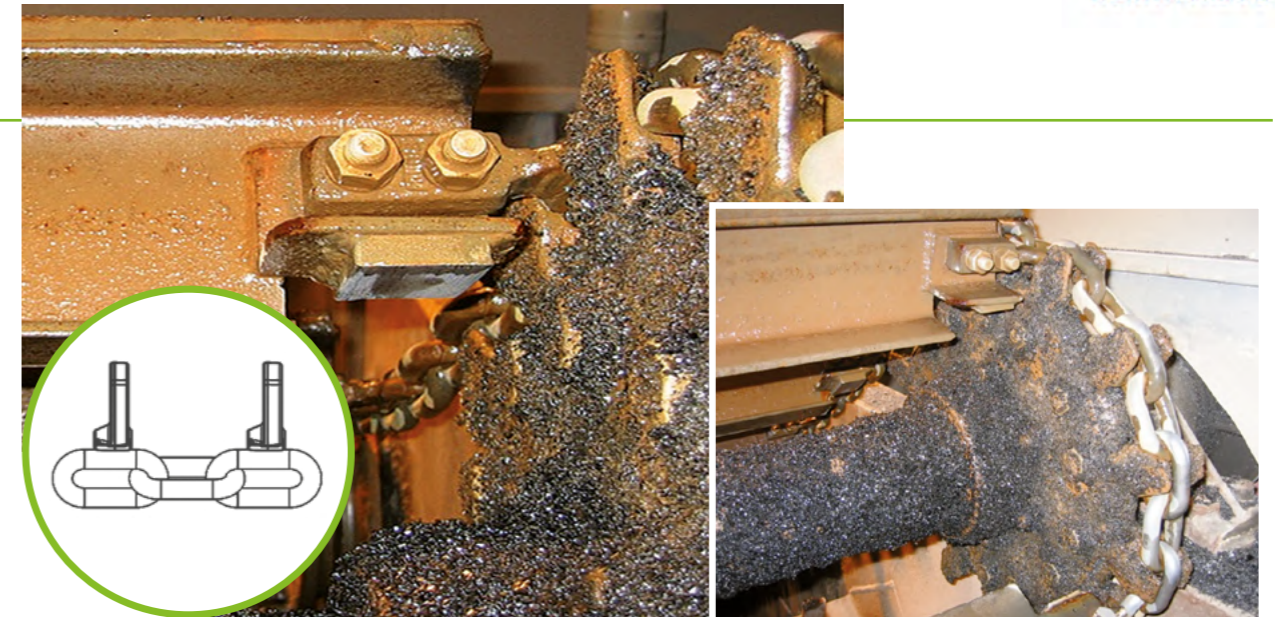

DE-ASHER WITH FM ATTACHMENT



LANDFILL WASTE BUNKER DISCHARGE WITH MEE-T ATTACHMENT

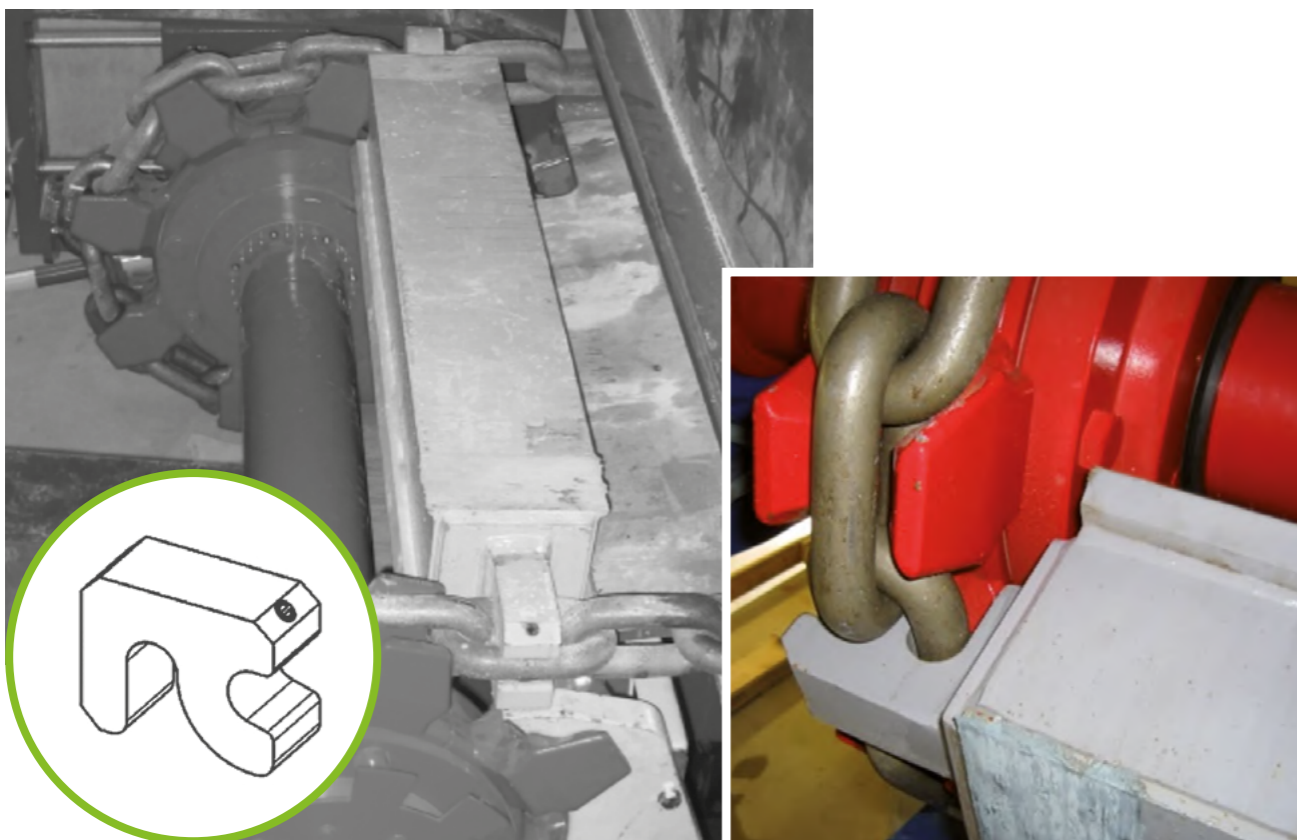

RECLAIMER SCRAPER BARS WITH SYSTEM 65

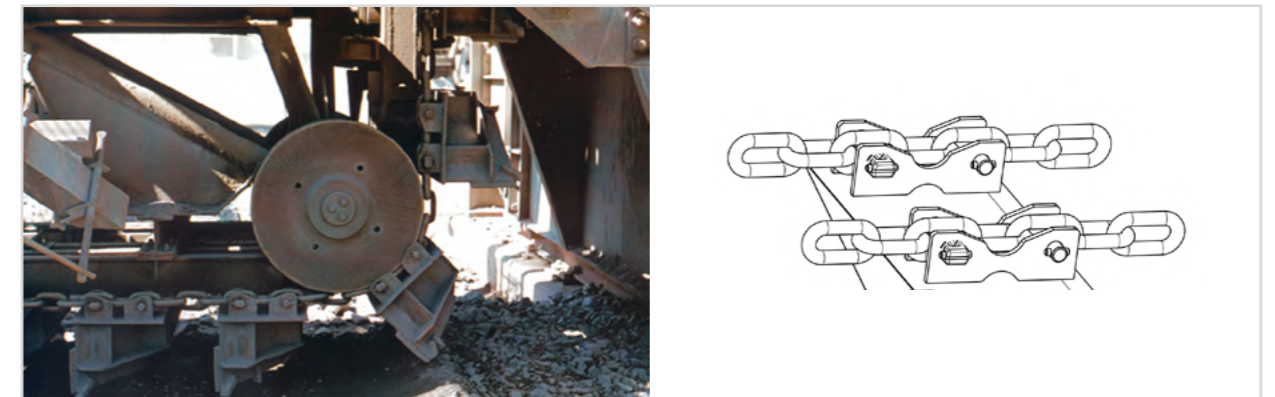

# RUD SYSTEM POCKET WHEELS

## MULTI-PART POCKET WHEEL SYSTEM

### Properties:

- With replaceable, highly wear-resistant pocket wheel discs
- For difficult operating conditions
- Preferably used as driving gear

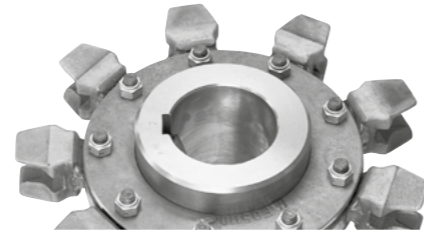

For chain d × t in mm	Z	PCD Ø	A	B	C	E <sub>max.</sub>	F <sub>max.</sub> = Hole Ø in mm	Complete sprocket wheel approx. kg / piece
10 × 38	8	195	35,0	80	30	80	45,0	6,5
14 × 50	8	256	49	120	35	100	80,0	13,1
	9	288	49	140	45	90	100,0	15,2
	10	320	49	155	40	105	100,0	23,8
	12	384	49	155	40	105	100,0	37,4
16 × 64	8	327	56	160	45	125	110	27,2
	10	409	56	195	45	125	140	45,4
18 × 64	8	328	64	150	45	125	90	30,5
19 × 75	8	384	66	185	45	145	130	40,5
	10	479	66	225	45	145	150	68,0
22 × 86	7	387	77	155	65	165	90	45,0
	8	440	77	200	65	165	120	59,5
	10	549	77	225	65	165	140	106,0
26 × 100	8	512	91	235	75	175	150	89,0
	10	639	91	335	75	175	230	215,0
30 × 120	9	690	108	320	80	170	180	189,0
	10	766	108	360	90	180	240	243,0
34 × 136	9	783,0	122,0	380	90,0	240	260,0	335,0
38 × 144	8	738,0	130,0	355	125,0	250	240,0	316,0

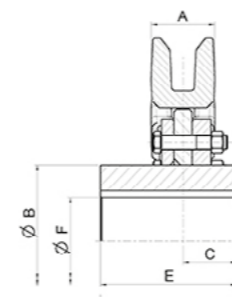
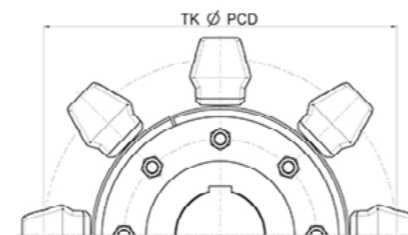

# RUD SYSTEM POCKET WHEELS

## SINGLE-PART POCKET WHEEL SYSTEM

### Properties:

- Highly wear-resistant
- For medium and difficult operating conditions
- Especially suitable as guide wheel

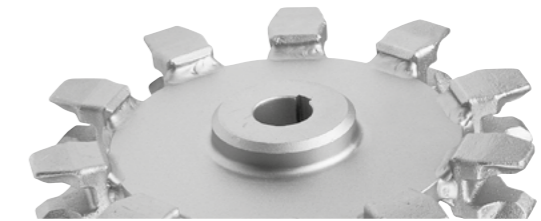

For chain d × t in mm	Z	PCD Ø	A	B	C	E <sub>max.</sub>	F <sub>max.</sub> = Hole Ø in mm	Complete sprocket wheel approx. kg / piece
8 × 31	5*	100,3	40	62	25,0	68	45,0	4,5
	6	119,7	45	-	22,5	45	40,0	2,9
	7	139,3	40	70	27,5	55	40,0	4,5
	10*	198,1	43	80	25,0	50	48,0	6,5
10 × 38	5*	123,0	55,0	75	32,0	80	45,0	3,5
	6	147,0	35,0	85	30,0	80	55,0	3,5
	8	194,7	35,0	100	25,0	80	65,0	11,5
	10*	243,0	35,0	100	30,0	80	65,0	21,0
14 × 50	6	193,0	49	105	30	75	70,0	7,5
	7	225,0	49	135	30	65	85,0	12,0
	8	256,0	49	120	30	100	80,0	13,5
	10	319,0	49	-	30	70	120,0	29,0
16 × 64	6	247,0	56	140	45	120	85,0	15,1
	8	328,0	56	160	45	125	120,0	21,5
	10	409,0	56	195	45	125	140,0	35,4
	12	383,0	49	160	30	100	120,0	23,5
18 × 64	6	247	63,5	140	45	120	95,0	20,1
	8	328	63,5	150	45	125	110,0	25,5
19 × 75	8	385	66,0	185	45	130	125,0	40,0
	10	479	66,0	225	45	145	150,0	50,0
22 × 86	6	332,0	77,0	-	50,0	100	140,0	27,0
	7	386,0	77,0	265	65,0	165	150,0	50,0
	8	440,0	77,0	185	65,0	165	135,0	50,5
	10	549,0	77,0	300	65,0	165	180,0	100,0
26 × 100	8	512,0	91,0	235	75,0	175	150,0	90,0
	10	639,0	91,0	335	75,0	175	250,0	110,0
30 × 120	8	614,0	108,0	320	55,0	210	220,0	180,0

\* without heat treatment

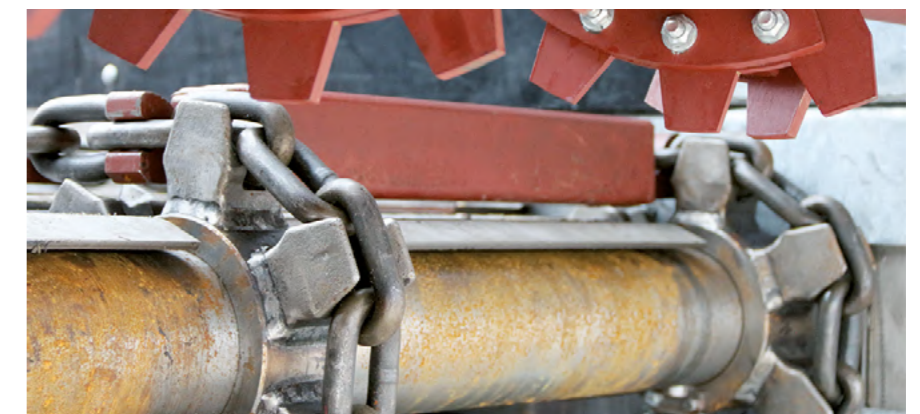
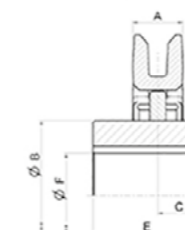
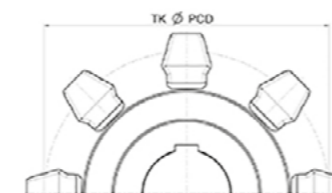

# RUD SYSTEM POCKET WHEELS

## ATTACHMENT MEE-T



### MEE-T IN ONE PART FOR SYSTEM POCKET WHEEL

**Properties:**

- For difficult operating conditions
- Scraper height up to 1.5 times the chain link width
- Double-strand conveyor and multiple-strand conveyor systems
- Can be welded to anything
- Securing with locking pin if necessary
- Run over pocket wheels and plain wheels
- Deliverable with and without locking pin.

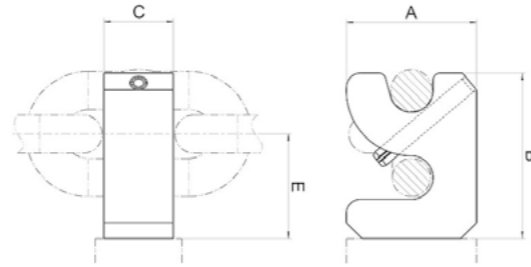

RUD Part no. with locking pin	RUD Part no. without locking pin	For chain d x t in mm	A	B	C	E	kg / piece
62930	62929	10 x 38	35	43	16	27	0,2
55158	50380	14 x 50	50	60	20	38	0,4
62676	50383	16 x 64	56	70	28	44	0,6
62677	50417	18 x 64	62	78	25	49	0,6
62678	50418	19 x 75	65	80	35	50	1,0
62680	50419	22 x 86	75	95	40	60	1,6
62681	50423	26 x 100	90	111	45	70	2,5
62683	50424	30 x 120	105	128	55	81	4,6
62685	50425	34 x 136	115	144	65	91	6,0
7992593	-	38 x 144	128	160	65	101	7,3

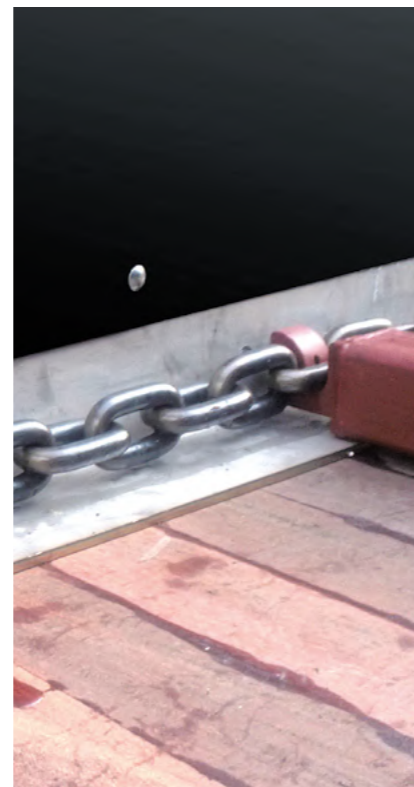
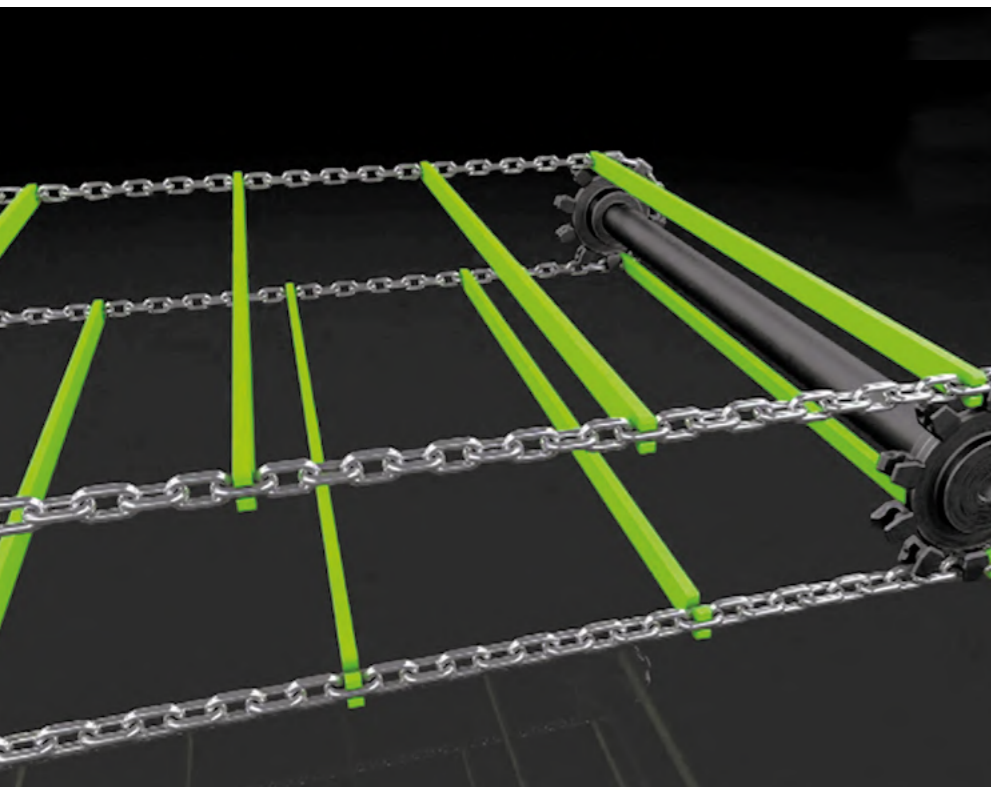

# RUD SYSTEM POCKET WHEELS

## ATTACHMENT MEZ-T



### PIVOT FITTING ATTACHMENT MEZ-T IN TWO PARTS-POCKET WHEEL

**Properties:**

- For medium to difficult operating conditions
- For scraper height up to 1.5 times the outer chain link width
- Assembly and disassembly of tensioned chain is possible
- Double-strand conveyor and multiple-strand conveyor systems
- Run over pocket wheels and plain wheels

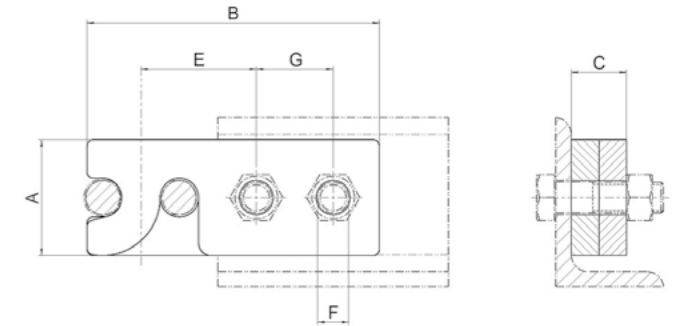

RUD Part no.	For chain d x t in mm	A	B	C	E	F	G	kg / Pair
7102680	10 x 38	35	100	12	37	11,0	30	0,3
62686	14 x 50	50	130	16	52	13,5	36	0,7
62687	16 x 64	56	150	24	58	17,5	40	1,3
63039	18 x 64	62	155	24	63	17,5	40	1,5
63040	19 x 75	65	165	30	65	17,5	46	2,0
62688	22 x 86	75	190	36	75	22,0	50	3,2
62689	26 x 100	90	220	44	86	22	60	5,5
62690	30 x 120	105	250	56	96	26	70	9,3



# RUD BUCKET ATTACHMENT SYSTEMS

## AT A GLANCE



### Problems of the DIN-Systems

- Chain bracket has a double function
- Transmission of tension of the chain loop
- Fixing the bucket to the chain loop and absorbing bucket strain
- Weak point double-function may lead to fatigue fractures
- Additional consequences may be loose screw fittings
- Even over-dimensioning in heavy conveyor operations does not solve these problems

### Solution RUD multi-link-fastenings 2win and System 65

- Assembly over several chain links
- No transmission of tension from the chain to the attachment
- Gentle introduction of the scooping force into the chain strand
- Minimising wear in the chain joints

	Bucket width [mm]	Max. conveyance capacity [m³/h]	Max. dimension between axles [m]		Max. conveyance speed [m/s]	Recommended granulation [mm]	Max. temperature of material to be conveyed [°C]	Recommended material to be conveyed
<b>RUD Central chain</b>	Recommended traction mechanism:			RU50, RU80, RU150, RU200; Breaking force 570–2000 kN				
	250–1100 einfach 2 × 250– 2 × 1000 tandem	600 1200	70		1,7	120	250	Cement, limestone, gravel, coke, slag, clinker
<b>RUD System 65</b>	Recommended traction mechanism:			Round link steel chain 14 × 50–34 × 136; Breaking force 140–720kN				
	250–1600	1100	65		1,5	120	200	Cement, limestone, gravel, coal, sugar beets, clinker, potassium, rock, salt, fertiliser, soda
<b>RUD System 2win*</b>	Recommended traction mechanism:			Round link steel chain 14 × 50–34 × 136; Breaking force 140–720 kN				
	250–1250	700	60		1,5	100	200	Cement, limestone, lump lime, soda, gypsum, fertiliser, filter dust
<b>RUD System RUca</b>	Recommended traction mechanism:			Round link steel chain 16 × 64 – 26 × 100; Breaking force 100 – 265 kN				
	250–630	20–210	35		0,9...1,4	Chain diameter x 0.5 to chain diameter x 1.2 depending on the application	200	Building materials, potash and salt, sugar, lime, gypsum, REA gypsum, filter dust, cement
<b>RUD System SWA</b>	Recommended traction mechanism:			Round link steel chain 16 × 64 – 30 × 120; Breaking force 180 – 640 kN				
	400–1250	30...275	40		0,6...0,8	100	200	Fertiliser, difficult to unload conveyed goods, for gentle transport of conveyed material
<b>RUD fabric belt</b>	Recommended traction mechanism:			Fabric belts are available with 4 – 6 EP 630 – EP 1600 inserts				
	160–1250	700	45		1,7	40	120	Cement, limestone, gypsum, sugar, coal, aluminium oxide, sand, potassium, rock salt, slag, filter dust
<b>RUD steel cord belt</b>	Recommended traction mechanism:			Steel cord belts are available with a breaking force of 800... 3150 N/mm belt width				
	315–1600	1200	120		1,7	80	120	Cement, limestone, coal, potassium, rocksalt slag

# RUD CHAIN ELEVATORS

## AT A GLANCE



These are specially designed for the dust free, vertical conveyance of powdery, granular, lumpy and high temperature bulk materials.

Highly wear-resistant chains, traction wheels or sprockets ensure that even abrasive materials are transported reliably. Specially designed chain type bucket elevators are available in either centrifugal / gravity, positive or central discharge designs dependent on the application

### CONVEYING CAPACITIES, REFERENCE VALUES FOR APPROX. 75% FILLING

		Bucket DIN 15233										
	Width [mm]	160	200	250	315	400	500	630	800	1000	1250	1600
	Conveyance speed [m/s]	1,05	1,05	1,15	1,15	1,20	1,20	1,34	1,34	1,48	1,48	1,48
	Conveyance capacity [m3/h]	9	11	20	25	44	61	94	129	196	305	391
		Bucket DIN 15234										
	Width [mm]	160	200	250	315	400	500	630	800	1000	1250	1600
	Conveyance speed [m/s]	1,05	1,05	1,15	1,15	1,20	1,20	1,34	1,34	1,48	1,48	1,48
	Conveyance capacity [m3/h]	14	17	31	39	70	98	151	207	304	473	605
		Special bucket										
	Width [mm]	160	200	250	315	400	500	630	800	1000	1250	1600
	Conveyance speed [m/s]	1,15	1,15	1,25	1,25	1,28	1,33	1,49	1,49	1,48	1,48	1,48
	Conveyance capacity [m3/h]	18	23	41	52	91	133	209	287	353	558	715
		High-capacity bucket conveyor										
	Width [mm]	160	200	250	315	400	500	630	800	1000	1250	1600
	Conveyance speed [m/s]	1,15	1,15	1,25	1,25	1,28	1,33	1,49	1,49	1,48	1,48	1,48
	Conveyance capacity [m3/h]	27	34	59	75	129	185	288	397	499	789	1010

### DIMENSIONS \*

Bucket width	b	160	200	250	315	400	500	630	800	1000	1250	1600
Head	a	724	724	904	904	1004	1160	1264	1460	1673	1747	1747
	c	560	560	695	695	785	885	955	1160	1320	1340	1340
	h	850	850	1050	1050	1250	1450	1600	1800	2100	2300	2300
Funnel	e	1000	1000	1250	1250	1400	1650	1800	2100	2450	2550	2550
	f	280	355	450	545	660	770	900	1110	1300	1600	2000
Foot	a	724	724	904	904	1004	1160	1264	1460	1673	1747	1747
	g	1220	1220	1350	1350	1500	1700	1900	2100	2450	2500	2500
	t	670	670	800	800	880	970	1080	1300	1550	1550	1550
	s	1320	1320	1450	1450	1600	1800	2000	2200	2750	2750	2750
Expansion Distance	E	900	1000	1200	1300	1500	1600	1800	2100	2500	2900	3500

Not permitted for snub roller & mid-discharge bucket elevators.

The bucket elevator casings are self supporting, but they require horizontal guides at least every 15 meters and below the elevator head. The bucket elevator head comprises a lower section with doors to access the adjustable discharge plate, and braced bearing mountings, for the pedestal bearings which support the drive shaft, the shaft exit points use grease filled radial shaft seals. The upper sections comprise a multipart removable hood with an inspection door. A drive platform is mounted on the side of the lower part of the head for supporting a wide variety of commercially available drives. If required a maintenance platform and or an overhead support/ service beam can be fitted if required. An elevator drive normally consists of a geared motor unit, which is normally connected to a frequency controller for maintenance purposes. For higher power requirements, we recommend a drive unit with a bevel spur gearbox, and standard motor optionally with ancillary drive. Starting characteristics can be optimised by a hydraulic clutch or an electric soft start.

The double or single leg casing is torsionally rigid sheet metal housing, constructed of standard section lengths with flange connectors. The maintenance and assembly door position should preferably be located in the elevators raising casing leg, approximately 0.8 m above a platform.

The elevator boot is optionally designed with either internal, oil-filled bearings or external pedestal bearings. With external bearings, the shaft exit points are sealed by gray cast-iron stuffing boxes. There are large assembly doors and cleaning doors on both sides. The chain takeup tension is generated by a weight or spring-loaded spindle take-up device.

Depending on the type of chain used, RUD driving wheels are either non-toothed chain pulleys with replaceable, highly wear-resistant segments, or toothed sprocket wheels with replaceable, highly wear-resistant teeth. The RUD return wheels have replaceable, highly wear-resistant segments which in certain designs incorporate guide discs.

Buckets are manufactured according to DIN or our works standard. The materials used are steel, stainless steel, or rubber.

Buckets are attached by chain shackles, bolted clamping clips, plug-in attachments or angle brackets.

The chains are either hardened, round link chains to DIN Standard or works standard chain designs made of special, highly wear-resistant alloy steel. Engineering style chains are also used, as either double or single central chains.

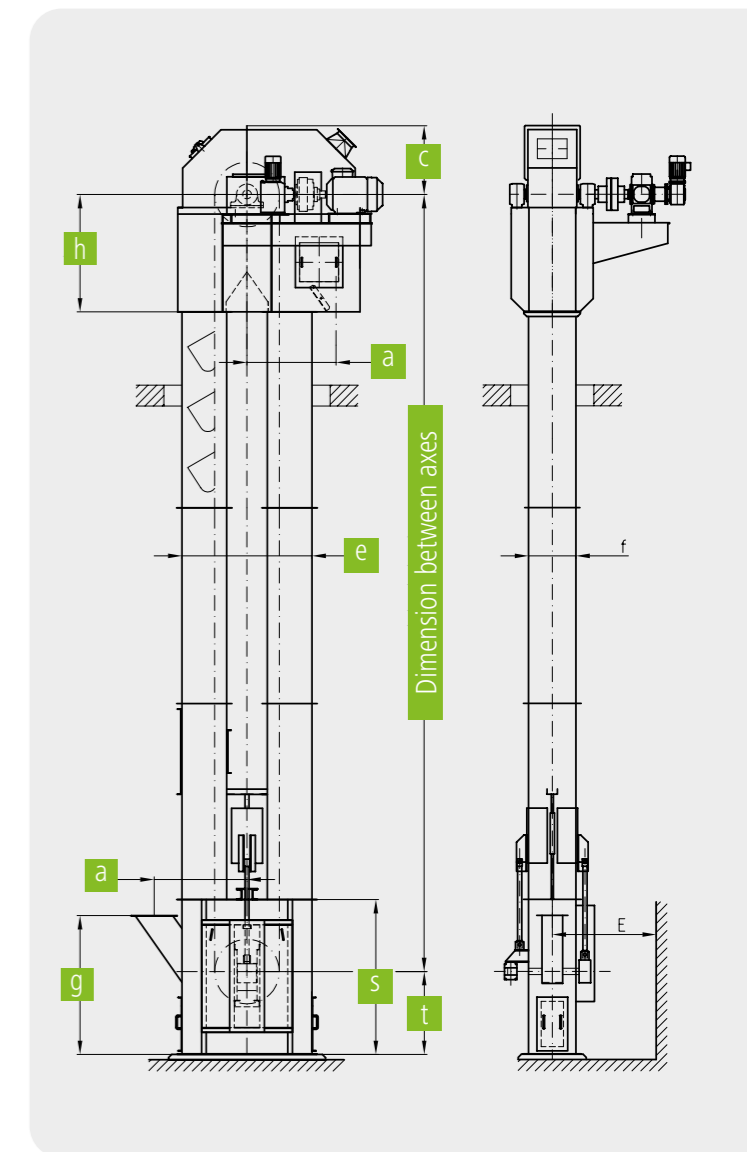

Standard safety devices such as speed governors and level indicators, to monitor the operating status of the bucket elevator are incorporated. Additional accessories are available.

# RUD RUca BACK-WALL BUCKET ATTACHMENT



SYSTEM COMPARISON		DIN	RUca	
		Single link-mounting	Single link-mounting	Multiple link mounting
	Brace support in the chain strand	+	+	+++
	Suitability for coarse-grained materials	+	+	+++
	Suitability for high capacity buckets			+++
	Wear and tear on attachments	++	+	+
	Wear and tear on chain	+	++	++
	Component break resistance	+	++	+++
	Soggy / viscous materials	+	+	++
	System reliability / availability	+	++	+++
	System / Chain, Safety	-	+	+

**RUca – The RUD alternative to DIN system**  
RUca only available as a system in conjunction with RUD chains and RUD chain connectors.

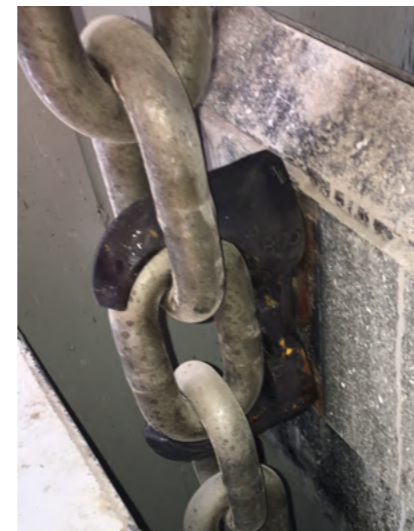

## BUCKET REAR MOUNTING RUca

**Properties:**

- RUD endless chain strands must be used
- Short assembly and disassembly times, without special tools
- Travel over plain wheels
- Higher component break resistance
- Suitable for replacing all the DIN bucket attachments in round steel link chain bucket elevators except side-wall attachments
- Less wear and tear on chain
- No oversized components



RUD Part no. RUca	RUD Part no. Testset <sup>*)</sup>	RUca Size	Chain d x t	Min. Breaking force	RUca dimensions							weight	Usual DIN bucket DIN 15 233 DIN 15 234	
					A	B	G	H	I	J	K <sup>*)</sup>			
[--]	[--]	[--]	[mm]	[kN]	[mm]	[mm]	[mm]	[mm]	[mm]	[mm]	[mm]	[mm]	[kg]	[mm]
7908918	7908536	26	26 x 100	265	190	53	M24	52	105	113	65 (105 / 60 / 50)	2.35	630 x 280	

\*1) in brackets: usual shackle acc. to DIN 5699 / DIN 745 and their dimension „a“ (shackle pitch / „a“ DIN 5699 / „a“ DIN 745)

\*2) includes 2 chain strands and RUca attachments for minimum 3 buckets

## MOUNTING SEQUENCE

1	2	3	4	5
Insert the bolts	Pivoting the upper RUca half into the chain	Pivoting the lower RUca half into the chain.	Insert the safety spring	Fix the bucket

## BACK-WALL BUCKET ATTACHEMENT RUca

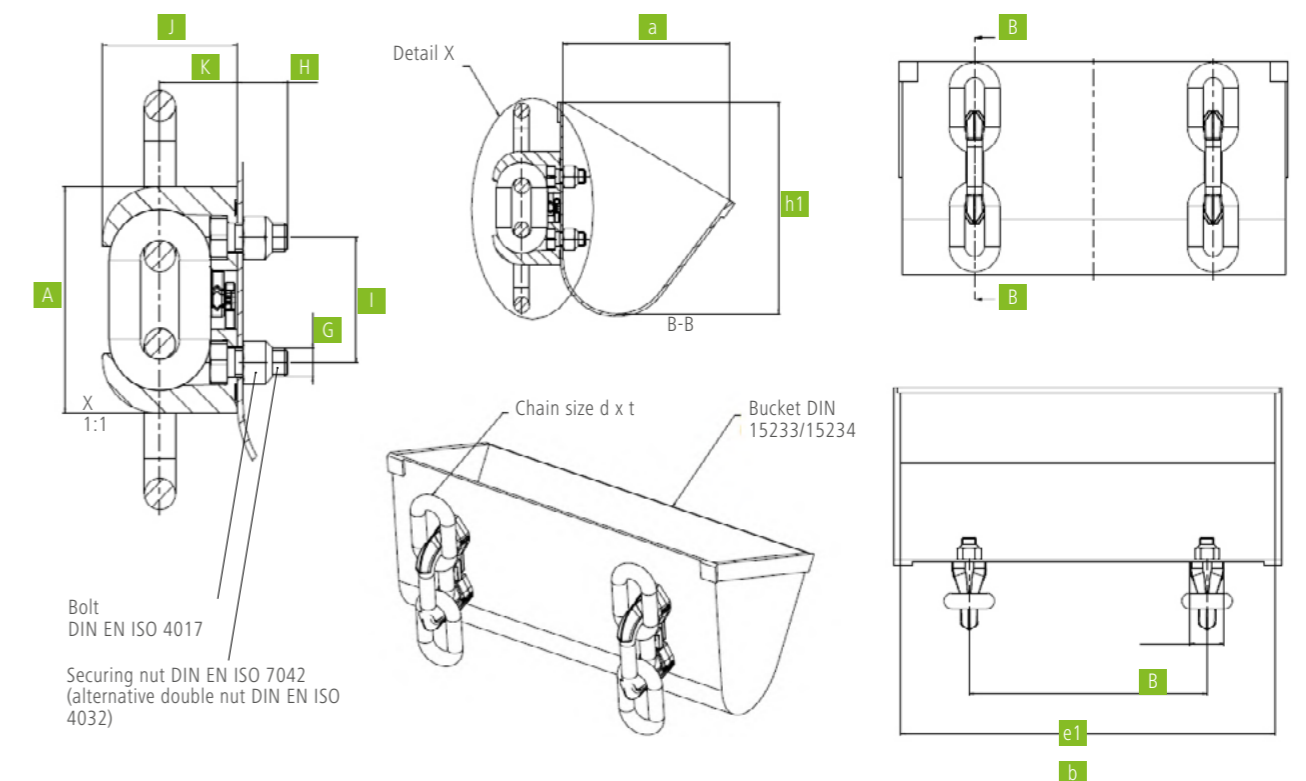

## RUD 2WIN BACK-WALL BUCKET ATTACHMENT

### Properties:

- For use bucket conveyors with up to 60m height
- Endless chain strands can be used
- Short assembly and disassembly times, without special tools
- Bucket attachments run over sprocket wheels and plain wheels

- Suitable for replacing all the DIN bucket attachments in round steel link chain bucket elevators except side-wall



RUD Part no.	chain d × t in mm	A	B	G	H	I	K <sup>*1)</sup>	weight [kg]
7998699	14 × 50	124	40	M14	30	56	39 (56 / 34 / 25)	0,85
7998700	16 × 64	156	43	M16	35	63	45 (70 / 42 / 34)	1,15
8503775	19 × 75	180	50	M20	40	80	53 (80 / 47 / 37)	1,7
8503776	22 × 86	207	58	M24	50	91	62 (91 / 52 / 43)	2,7
8503777	26 × 100	240	60	M24	50	105	71 (105 / 60 / 50)	3,4
7996145	30 × 120	288	75	M30	60	126	84 (126 / 71 / 59)	6,5
7993608	34 × 136	327	92	M36	70	147	96 (147 / 81 / 68)	10,2

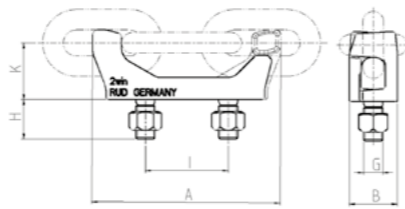

\*1) in brackets: usual shackle acc. to DIN 5699 / DIN 745 and their dimension „a“ (shackle pitch / „a“ DIN 5699 / „a“ DIN 745)

### ASSEMBLY SEQUENCE

1	2.1	2.2	3	4
Rotate the brackets against each other	Thread 2win in the chain	Close 2win	Mount the brackets	Mount the buckets

## RUD SWA SIDE-WALL ATTACHMENT

### Properties:

- For use in slow-running bucket elevators with gravity drain, central discharge bucket conveyors and return-feed bucket conveyors
- Endless chain strands can be used
- Easy assembly in case of variable bucket distance

### distance

- Two-link bucket attachment for a smooth run across the sprocket wheels



RUD Part no.	chain d × t in mm	A	B	G	H	I	K	weight [kg]
7992042	16 × 64	140	81	M16	35	105	37	0,6
7982949	19 × 75	164,4	98,5	M20	40	124	47	1,3
7992040	22 × 86	190	112	M20	40	145	51	1,4
7987910	26 × 100	224	130,5	M24	45	170	60	2,8
7990871	30 × 120	258,5	153,5	M30	55	198,5	71	3,5

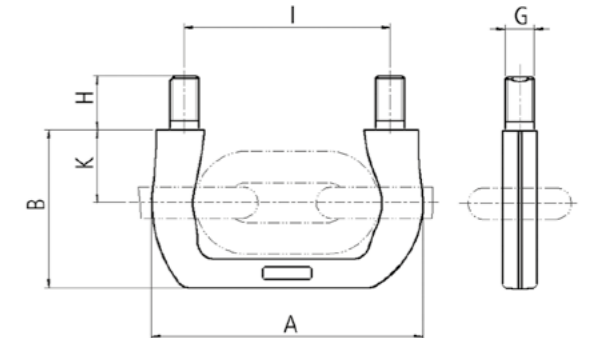

### ASSEMBLY SEQUENCE

1	2	3	4
For central discharge bucket elevators	Positive discharge bucket elevators		

# RUD CHAIN WHEEL

FOR BUCKET ELEVATORS 2WIN, RUCA, SWA

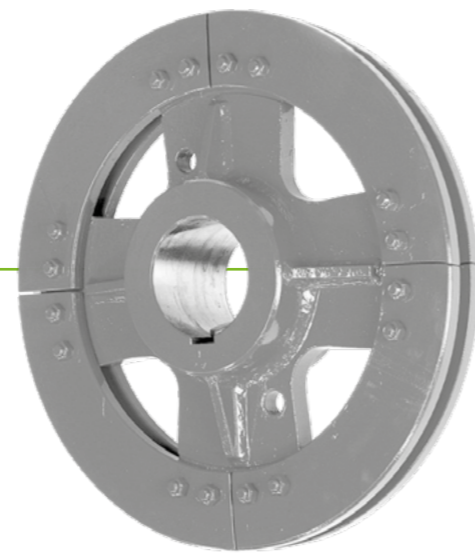

Special grooved wheels and guide wheels on request.

Spare parts:  
Per chain roller a set of segments

- Properties:**
- Especially suitable for RUD systems 2win and SWA
  - Finish-drilled and grooved as per customer requirement
  - Robust welded construction with replaceable bearing ring segments
  - Hardened bearing ring segments for the drive
  - Unhardened bearing ring segments for deflection

Chain d × t in mm	TK Ø	B	C	D	Weight of the complete sprocket approx. kg / piece
14 × 50	500	19	55	120	70
16 × 64	630	22	62	140	135
19 × 75	710	27	71	160	170
22 × 86	800	29	79	170	250
26 × 100	900	33	93	200	350
30 × 120	1000	40	110	200	450
34 × 136	1250	44	114	220	500

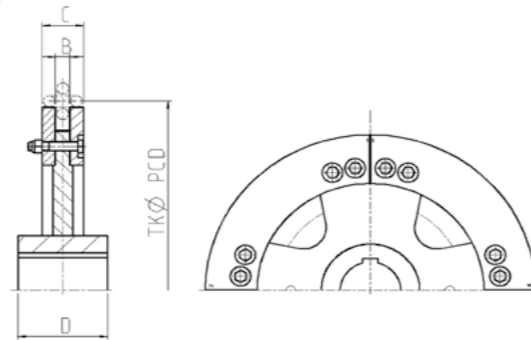

## ASSEMBLY OF CHAINS ACROSS THE SMOOTH DRIVE CHAIN WHEELS IN THE BUCKET ELEVATOR

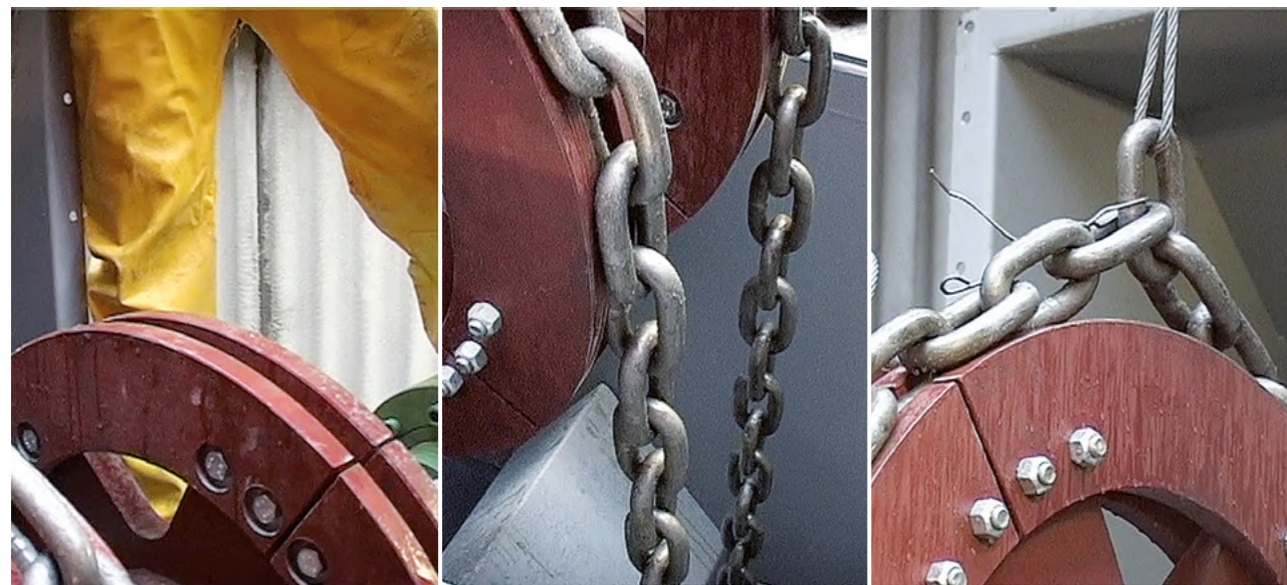

# RUD BUCKET ATTACHMENT

SYSTEM 65



System 65 – RUD bucket attachment: NEW with integrated wear mark

Chain d × t in mm	Flat steel single part	Plug in attachment flat	Plug in attachment round	A	B	C	D	E	F	G	H	Complete weight [kg]
14 × 50	7908368	61160	61162	150	55	8	33	25	100	49	93	1.0
16 × 64	7908380	61163	61165	190	65	10	40	31	128	58	110	1.9
19 × 75	7908381	61166	61168	230	75	12	45	40	150	68	130	3.0
22 × 86	7908382	61169	61171	260	85	12	50	44	172	80	158	4.6
26 × 100	7908383	61172	61173	290	100	12	61	45	200	94	172	6.4
30 × 120	7908384	61174	61175	340	125	12	75	50	240	109	190	9.7
34 × 136	7908386	54713	54714	380	130	15	80	54	272	122	210	12.8

- Properties:**
- For heavy operating conditions in the bucket elevator area
  - Robust and highly wear-resistant
  - Easy assembly and disassembly of buckets on the chain

The complete version includes the following components:

- 4 × flat steel part with wear mark and wear-resistant steel
- 1 × plug-in attachment round
- 1 × plug-in attachment flat

A repeat order for individual parts such as flat steels and plug-in attachments can also be placed separately

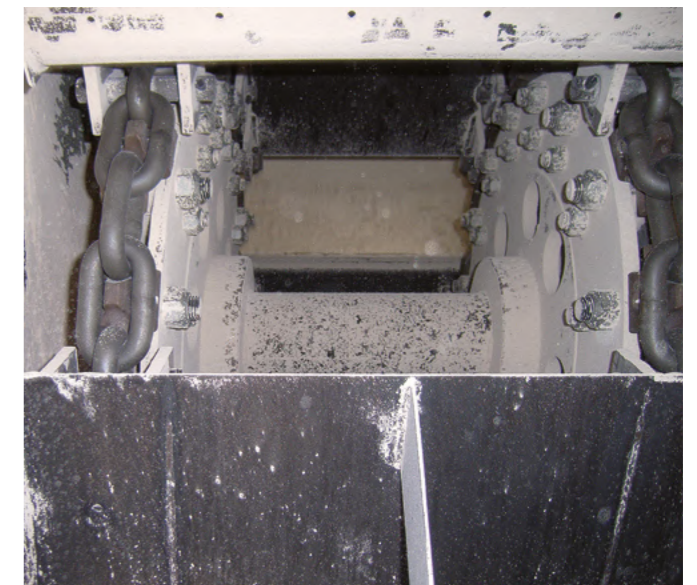
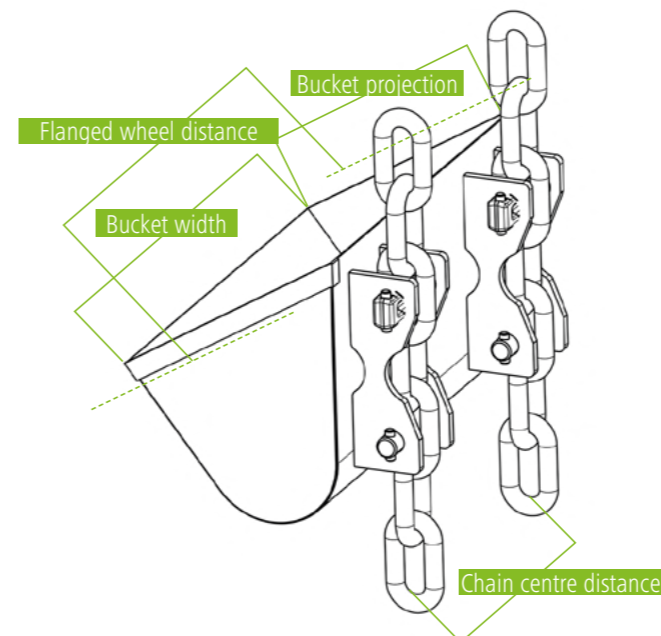
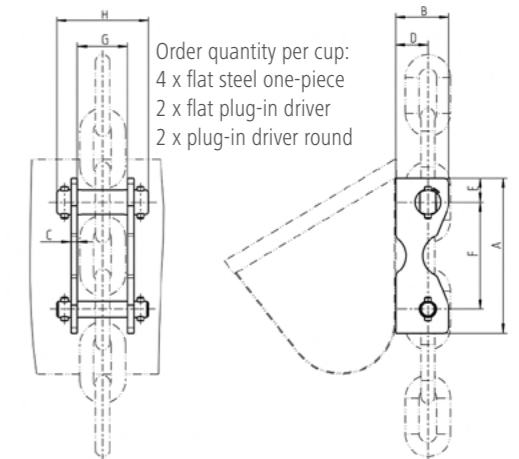

# RUD REVERSING WHEEL FOR BUCKET ELEVATORS

SYSTEM 65



- Properties:
- The bearing ring and the hub plate are stable welded constructions
  - Weight-loaded initial tensioning is not required at the deflection due to the interlocked drive. The chain is redirected into uncompressed condition  
→reduction in wear

Support Ø G	A	C	E	Weight kg / Piece	Order numbers		
					Tread	Guide disk	Reversing wheel
540	110	70	140	120	55148	58287	59846
575	100	70	140	125	57571	58153	59847
630	100	70	140	135	57567	58104	59848
730	120	70	140	185	57599	58163	59849
800	120	80	160	210	57615	58204	59851
870	140	80	160	250	57618	58284	59867
980	190	80	160	420	57642	58285	59875
1095	190	80	160	510	57638	58192	59918
1180	195	100	200	620	59810	58280	59929
1280	195	70	140	560	59839	58296	60001

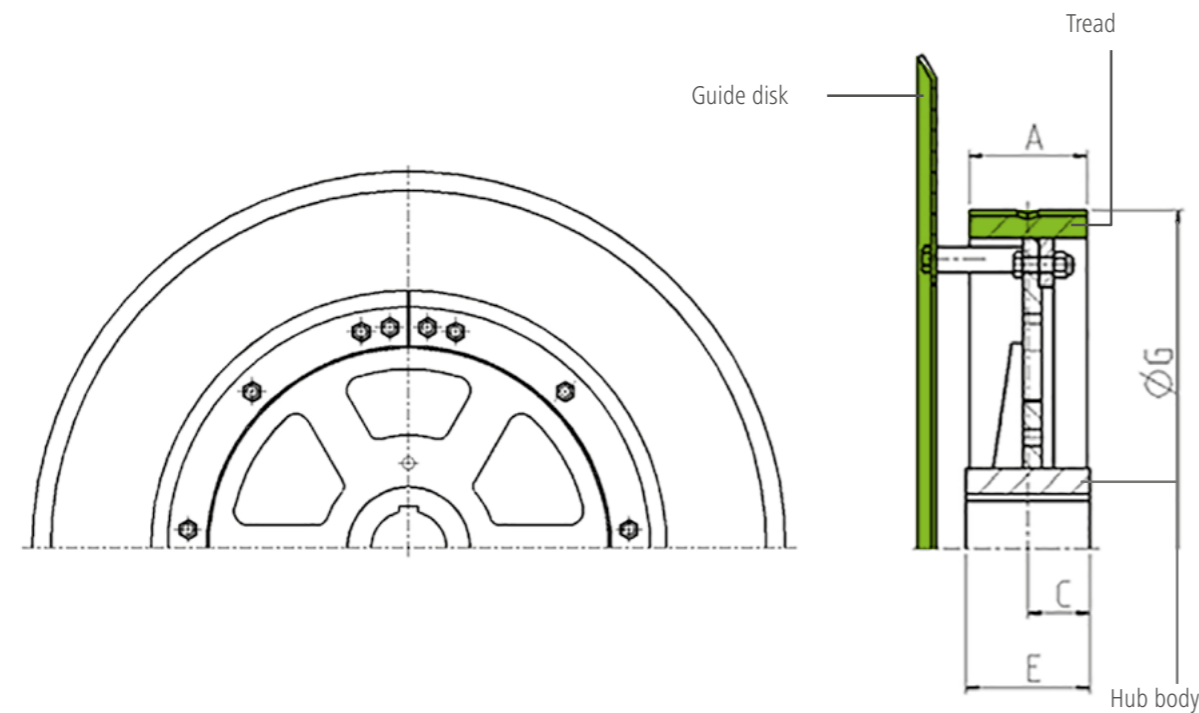

# RUD SPROCKET WHEEL

SYSTEM 65

## SPROCKET WHEEL WITH REPLACEABLE INDIVIDUAL TEETH <sup>1</sup>

- Properties:
- Replaceable individual teeth are made of MnCr special steel
  - The teeth are highly wear-resistant
  - Surface hardened
  - Hub and secondary sheaves are welded construction

Chain d × t in mm	Teeth	PCD Ø	B	C	E	weight kg / piece
14 × 50	16	510	160	50	110	71
	20	637	200	85	170	115
16 × 64	15 *	612	200	85	170	125
	17	694	201	75	150	148
	18	734	200	75	150	121
	20	816	210	90	180	148
19 × 75	15 *	718	240	75	150	132
	17	813	280	75	150	209
	19	908	270	90	180	289
22 × 86	15 *	823	275	90	180	238
	16	878	275	90	180	242
	17	932	270	90	180	299
	18	986	300	100	200	350
26 × 100	14 *	894	300	100	200	270
	15	956	300	100	200	290
	16	1020	300	100	200	403
	17	1084	300	100	200	410
30 × 120	14 *	1072	300	100	200	409
	15	1148	380	100	200	371
	16	1225	300	100	200	446
	17	1300	325	125	250	501
34 × 136	14 *	1214	370	100	200	489
	15	1301	370	100	200	488
	16	1387	390	110	220	677

<sup>1</sup> Other dimensions on request

TEETH WITH INCREASED LINK SUPPORT ALSO AVAILABLE. REFER TO PAGE 20.

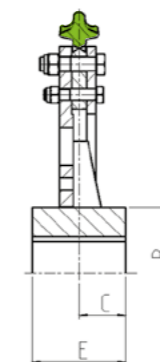
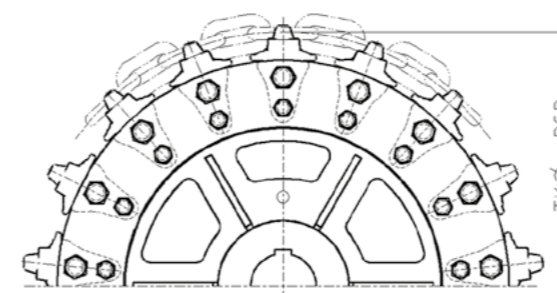

## RUD CENTRAL CHAIN INTEGRATED MOUNTING BRACKET

RUD central chains are ideal for use in high-performance bucket elevators and elevators in conveyor technology. For vertical conveying of powdery, granular, lumpy and temperature-loaded materials, the RUD central/link chain is a robust traction device.

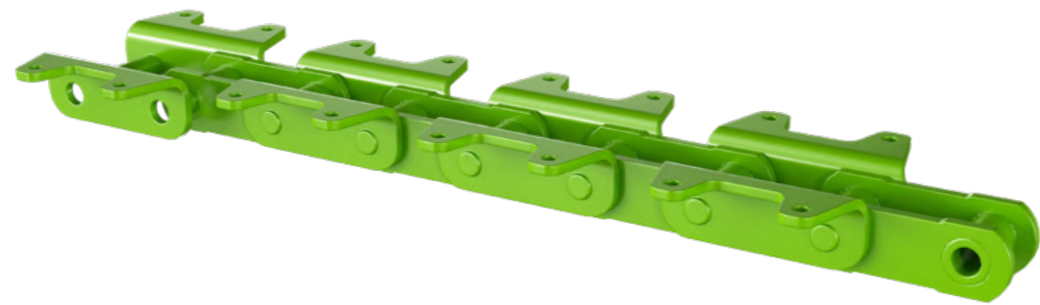

Chain size	Part No.	P	LW	B <sup>1</sup>	L <sup>1</sup>	Weight <sup>2</sup> [kg/m]	Strand length [mm]	Breaking force [kN]	h	d4	Usual bucket width [mm]
RU 40	8505869	140	51	140	100	20,3	2800	400	45	14	200...400
RU 55	8505874	152,4	66	200	130	31,3	3048	550	50	18	250...450
RU 70	8505876	152,4	71	250	150	40	3048	700	55	18	300...630

<sup>1</sup> customisable  
<sup>2</sup> incl. mounting bracket

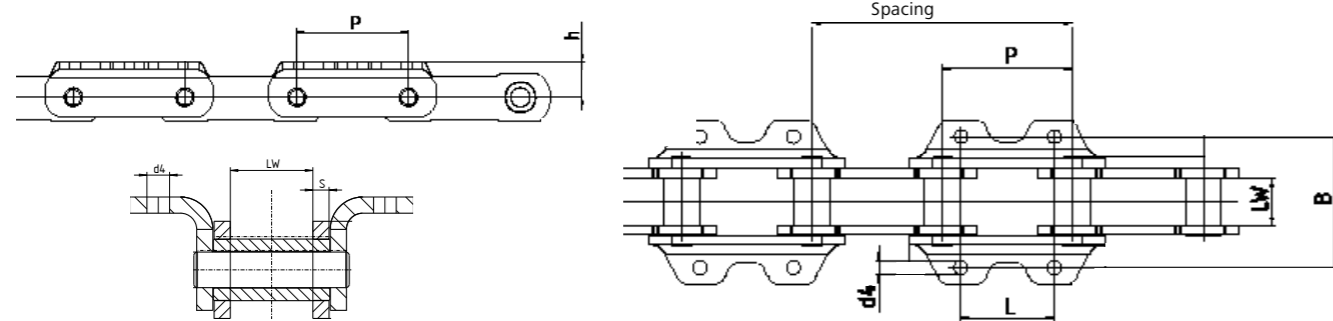

## RUD CENTRAL CHAIN WITH SEPARATE MOUNTING BRACKET

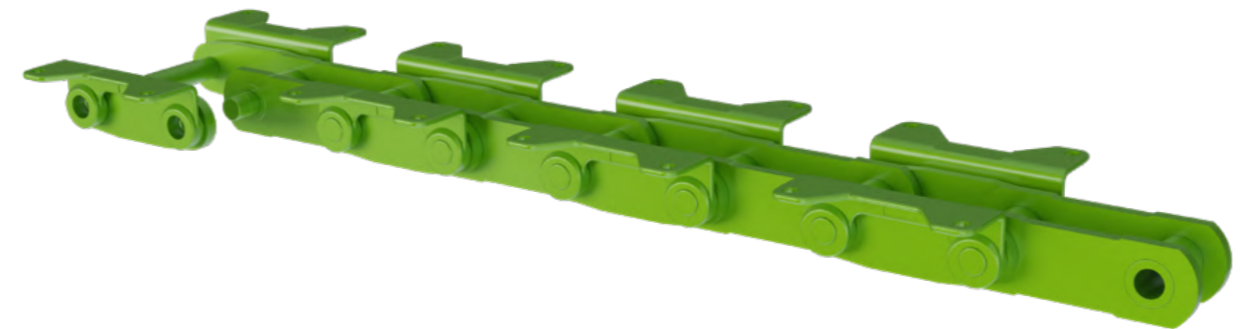

Chain size	Part No.	P	LW	B <sup>1</sup>	L <sup>1</sup>	Weight <sup>2</sup> [kg/m]	Strand length [mm]	Breaking force [kN]	h	d4	Usual bucket width [mm]
RU 80	on request	177,8	71	283 / 250	200 / 150	45,2	3556	1000	60	17,5	400...800
RU 100	8505878	177,8	71	283 / 250	200 / 150	45,2	3556	1000	60	17,5	400...800

<sup>1</sup> customisable  
<sup>2</sup> incl. mounting bracket

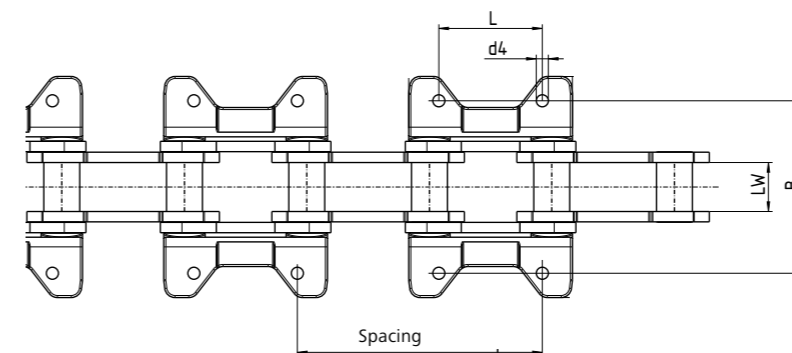
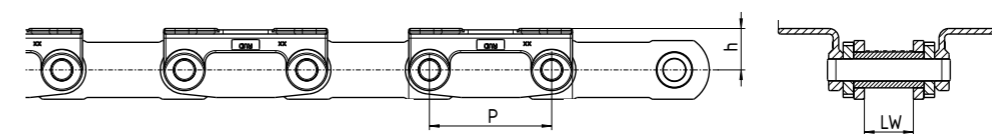

# RUD CENTRAL CHAINS

RU50 // RU80 // RU150 // RU200

## CENTRAL CHAINS

Part number chain	Order number Angle	Chain size	Strand length [mm]	Pitch [mm]	Breaking force [kN]	Possible bucket distance [mm]	Usual bucket width [mm]
7905523	6 × 8504351	RU150	1080	180	1500	360	400–1000
7992038	Chain incl. bracket	RU200	1080	180	2000	360	600–1100

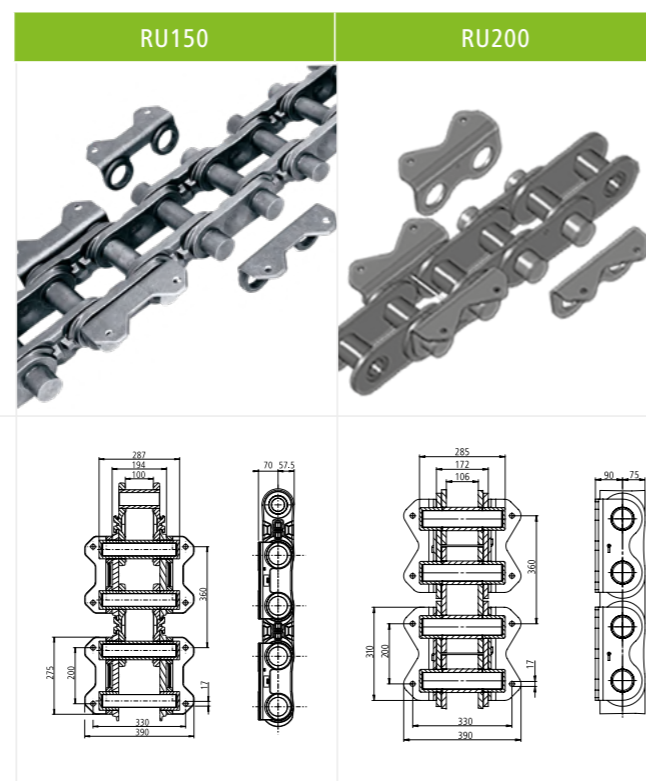

## DRIVE WHEEL

## TENSION SPROCKET

Drive wheel PCD Ø [mm]	B max [mm]	E max [mm]	Weight approx. [kg]	B max [mm]	E max [mm]	Weight approx. [kg]	Usual chain size
645	300	200	172	200	120	127	RU40 / RU55
700	300	200	195	200	120	147	RU40 / RU55 / RU70
800	400	360	480	220	200	300	RU70 / RU80 / RU100 / RU150
900	400	360	570	220	200	360	RU80 / RU100 / RU150
960	370	220	390	220	200	460	RU80 / RU100 / RU150
1000	400	300	740	220	200	550	RU80 / RU100 / RU150
1170	420	300	880	220	200	700	RU150 / RU200
1300	450	300	970	220	200	765	RU150 / RU200

- Properties:
- Running threads made of Cr-Mo steel
  - Running surface inductively hardened

RUD Drive Wheel



RUD Tension sprocket

RUD Tension sprocket can be toothed and non-toothed

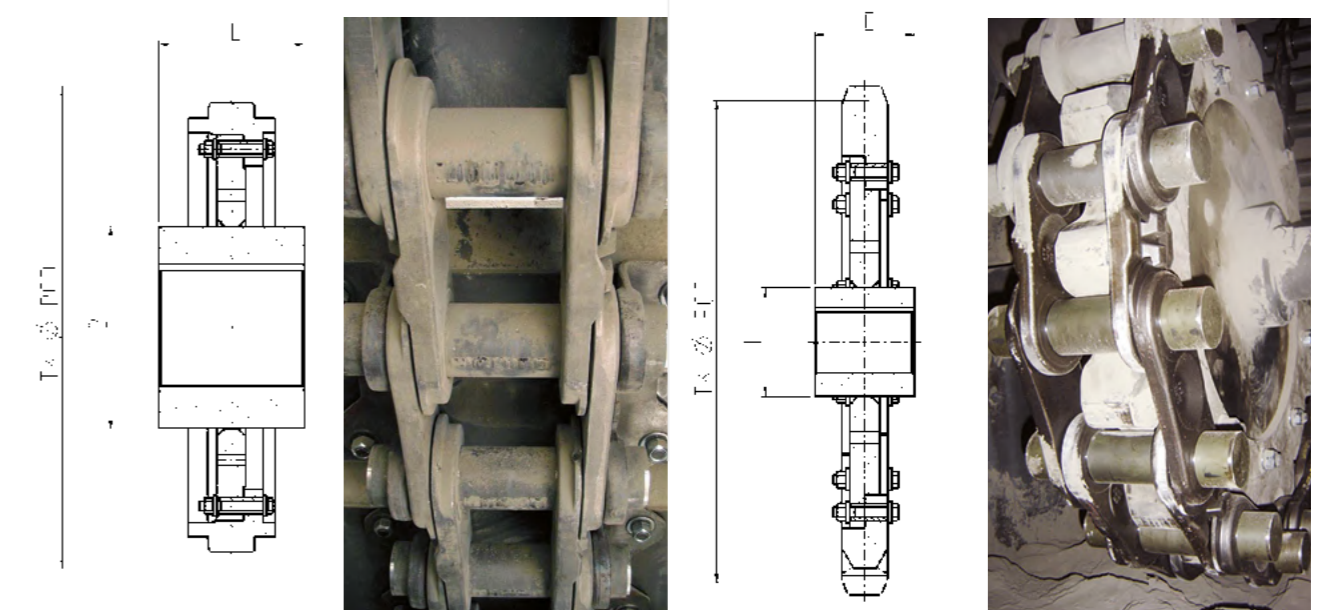
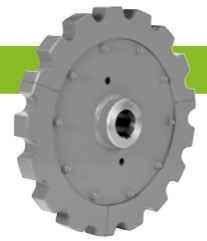

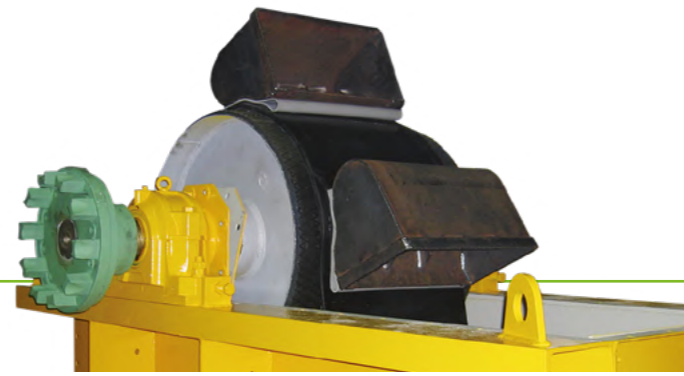

# RUD BELT TYPE BUCKET ELEVATORS

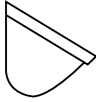

Belt type bucket elevator designs using textile or steel reinforced belts transport materials dust-free without difficulty, even to great heights and are especially suitable for the continuous vertical conveyance of free flowing bulk materials. Suitable adaptations are made to handle coarse-grained or higher temperature materials.

## CONVEYING CAPACITIES, REFERENCE VALUES FOR APPROX. 75% FILLING

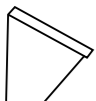
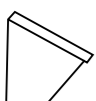
		Bucket DIN 15233										
	Width [mm]	160	200	250	315	400	500	630	800	1000	1250	1600
	Conveyance speed [m/s]	1,05	1,05	1,15	1,15	1,20	1,20	1,34	1,34	1,48	1,48	1,48
	Conveyance capacity [m³/h]	10	12	25	31	45	63	99	140	224	316	405
		Bucket DIN 15234										
	Width [mm]	160	200	250	315	400	500	630	800	1000	1250	1600
	Conveyance speed [m/s]	1,05	1,05	1,15	1,15	1,20	1,20	1,34	1,34	1,48	1,48	1,48
	Conveyance capacity [m³/h]	16	20	38	48	71	101	160	225	348	490	627
		Special bucket										
	Width [mm]	160	200	250	315	400	500	630	800	1000	1250	1600
	Conveyance speed [m/s]	1,15	1,15	1,25	1,25	1,28	1,33	1,49	1,49	1,48	1,48	1,48
	Conveyance capacity [m³/h]	25	32	56	70	105	154	246	353	512	726	930
		High-capacity bucket conveyor										
	Width [mm]	160	200	250	315	400	500	630	800	1000	1250	1600
	Conveyance speed [m/s]	1,15	1,15	1,25	1,25	1,28	1,33	1,49	1,49	1,48	1,48	1,48
	Conveyance capacity [m³/h]	27	34	64	81	134	198	321	480	652	850	1088

## DIMENSIONS

Bucket width	b	160	200	250	315	400	500	630	800	1000	1250	1600
Head	a	724	724	904	904	1004	1160	1264	1460	1673	1747	1747
	c	560	560	695	695	785	885	955	1160	1320	1340	1340
	h	850	850	1050	1050	1250	1450	1600	1800	2100	2300	2300
Funnel	e	1000	1000	1250	1250	1400	1650	1800	2100	2450	2550	2550
	f	280	355	450	545	660	770	900	1110	1300	1600	2000
Foot	a	724	724	904	904	1004	1160	1264	1460	1673	1747	1747
	g	1220	1220	1350	1350	1500	1700	1900	2100	2450	2500	2500
	t	670	670	800	800	880	970	1080	1300	1550	1550	1550
	s	1320	1320	1450	1450	1600	1800	2000	2200	2750	2750	2750
Expansion distance	E	900	1000	1200	1300	1500	1600	1800	2100	2500	2900	3500

The bucket elevator casings are self supporting, but they require horizontal guides at least every 15 meters and below the elevator head. The bucket elevator head comprises a lower section with doors to access the adjustable discharge plate, and braced bearing mountings, for the pedestal bearings which support the drive shaft, the shaft exit points use grease filled radial shaft seals. The upper sections comprise a multipart removable hood with an inspection door. A drive platform is mounted on the side of the lower part of the head for supporting a wide variety of commercially available drives. If required a maintenance platform and or an overhead support / service beam can be fitted if required. An elevator drive normally consists of a geared motor unit, which is normally connected to a frequency controller for maintenance purposes.

For higher power requirements, we recommend a drive unit with a bevel spur gearbox, and standard motor optionally with ancillary drive. Starting characteristics can be optimised by a hydraulic clutch or an electric soft start.

The double or single leg casing is a torsionally rigid, sheet metal housing constructed of standard section lengths with flange connectors. The maintenance and assembly door position should preferably be located in the elevators raising casing leg, approximately 0.8 m above a platform.

The elevator boot is optionally designed with either internal, oil filled bearings or external pedestal bearings. With external bearings, the shaft exit points are sealed by gray cast-iron stuffing boxes. There are large assembly doors and cleaning doors on both sides. The belt take-up tension is generated by a parallel weight or spindle take-up device.

Whereas the parallel weight take-up automatically compensates for belt stretch, the spindle take-up requires manual readjustment. The driving pulley has a structured rubber covering. Easy to replace, bolt-on, dished rubberised segments are available upon request.

The take-up pulley is designed as a cage drum. internal cones guide any material that enters the drum out to the sides.

The buckets are manufactured according to din or our works standard. The materials used are steel, stainless steel, aluminum, plastic or rubber. The bucket attachments are selected according to the loads to be handled. Rubber strips are fitted between the belt and the backs of the buckets. The buckets are attached by means of belting bolts, spherical or half round segments with countersunk bolts. The belts are available with textile or wire-cable reinforcement. Hot-material rubber compounds are used for transporting high-temperature materials. The belt is jointed by mechanical connecting brackets or claw connectors. Belts with a low linear expansion can be continuously vulcanised.

Standard safety devices, comprising off-track governors, speed governors and level indicators, to monitor the operating status of the

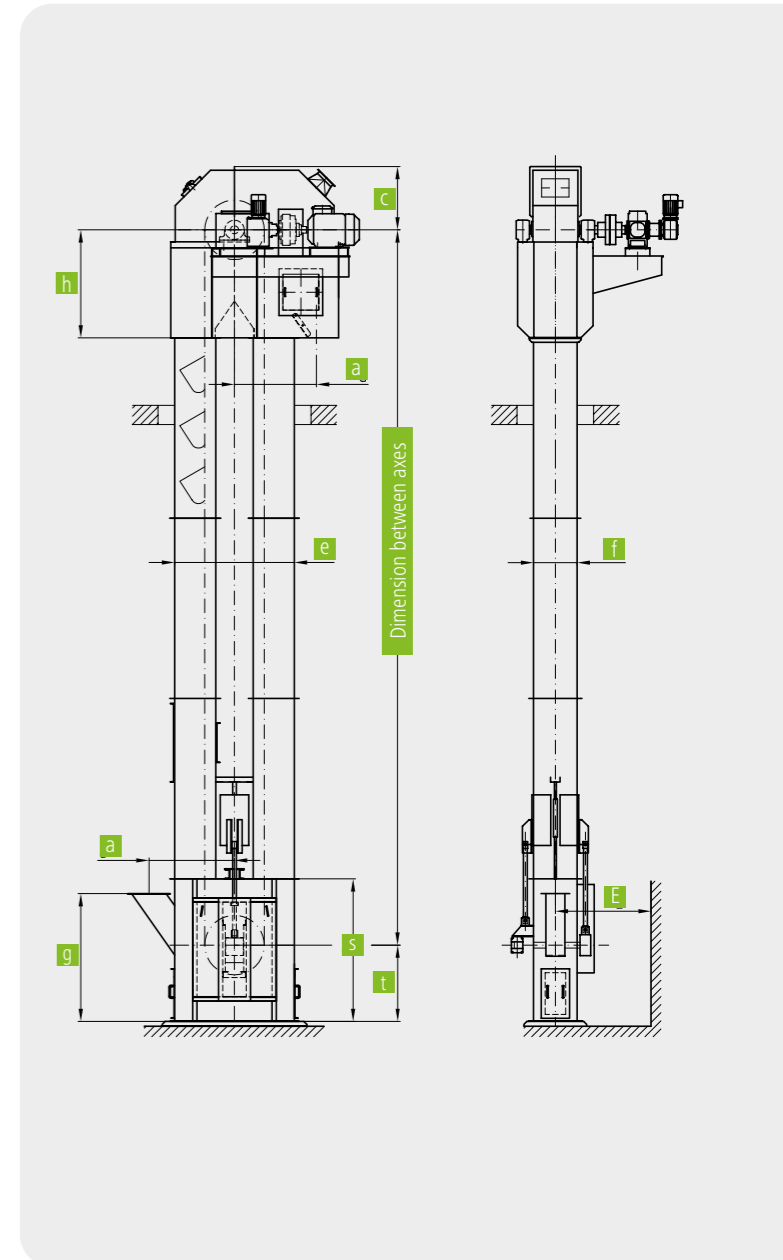

bucket elevator are incorporated.

Additional accessories are available brackets or claw connectors. Belts with a low linear expansion can be continuously vulcanised.

## RUD BELT TYPE BUCKET ELEVATORS



### THE RUD DRIVE DRUM DESIGN, WITH A CYLINDRICAL CENTRAL SECTION AND LATERALLY DECREASING DIAMETER

- Uniform load distribution across the width of the belt
- Low wear on the friction lining
- Stable running of the belt
- A longer service life for the belt



### THE RUD DRIVE DRUM DESIGN WITH INTERCHANGEABLE FRICTION LINING:

- The friction lining is easily exchangeable when worn
- It can be exchanged without removing the drum or opening the belt
- This makes it easier to maintain
- Reduces down times
- The segments can be re-used after replacing the rubber



### THE RUD PARALLEL TENSION UNIT:

- Automatic extension compensation of the belt
- A low pretension force and hence low loading
- Stable running of the belt
- A maintenance-free design

## RUD BUCKET ATTACHMENTS // STEEL-CABLE BELTS

### RUD STEEL-CABLE BELTS HAVE:

- A tensile strength of 800-3150 n / mm belt width and a low linear elongation of maximally 0.3%. This means that the belt never needs shortening during its entire service life.
- Steel cross-bracing on both sides to give high transverse rigidity, and so optimal straight running and high tear out strength of the buckets.
- Hot material rubber compositions for conveying material at a continuous temperature of up to 130°C, and temperature resistance up to a maximum 10° C peak load.
- 5 mm thick cover plates on both sides and solid rubber edge protection for a long service life, even when handling highly abrasive materials.
- Bucket attachment holes cut by water jet to ensure the highest quality.
- Belt ends prepared in the works for endless connection with mechanical belt connectors. Endless closure can also be achieved by hot vulcanisation.



### RUD BUCKET ATTACHMENTS:

- Have soft rubber inserts between the backwalls of the buckets and the belt, which prevent the material jamming and reduce the effects of heat on the belt.
- Can optimally adapt to the convexity of the drums.
- Always have the optimal fastening element for the particular load.
- Have extremely high tear-off strength when used with steelrope belts, even in the coarse grain range.

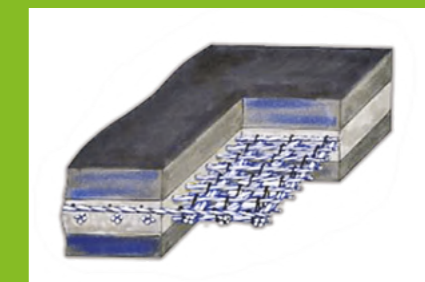
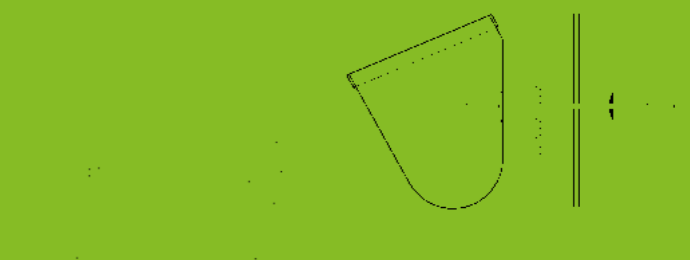

## RUD TROUGH CHAIN CONVEYOR

Trough chain conveyors are especially suitable for the dust-free, horizontal and moderately inclined transport and metering of bulk materials, including coarser type material. Trough chain conveyors combine high wear and heat resistance with the option of multiple inlets and outlets. We also supply a special version with cleaning scrapers.

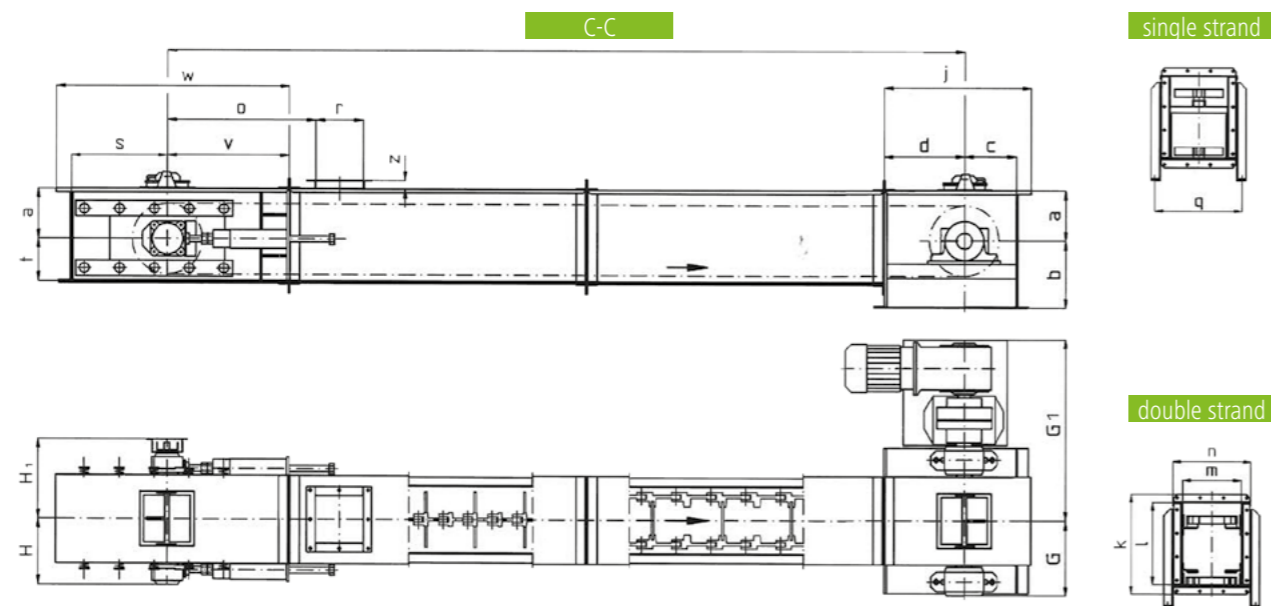

### CONVEYANCE CAPACITY IN CASE OF HORIZONTAL CONVEYOR / REFERENCE VALUES

Types	B	200	250	315	315	400	500	630	800	1000	1250
Chain		Single strand			Double strand						
Conveyance speed [m/s]	0,25	0,25	0,25	0,25	0,25	0,25	0,25	0,25	0,25	0,25	0,25
Conveyance capacity [m <sup>3</sup> /h]											
With chain guide	m <sup>3</sup> /h	–	–	–	21	45	83	128	244	316	406
Without chain guide	m <sup>3</sup> /h	23	36	45	56	92	126	158	288	360	450

### DIMENSIONS

Types	B	200	250	315	315	400	500	630	800	1000	1250
Drive station	a	210	210	210	298	298	298	298	405	405	405
	b	340	340	340	450	450	450	450	610	610	610
	c	230	230	230	300	300	300	300	400	400	400
Trough	d	370	370	370	450	450	450	450	600	600	600
	l	405	405	405	528	528	528	528	730	730	730
Tensioning station	m	260	310	375	375	460	560	690	860	1060	1310
	o	910	910	935	935	1020	1065	1115	1290	1385	1490
	z	53	53	53	53	53	53	53	64	74	74
	t	195	195	195	230	230	230	230	325	325	325
	s	550	550	550	550	550	550	550	550	550	550



The drive station has flange or pedestal bearings for the drive shaft, depending on the size. Sealing is provided by grease filled, double radial shaft seals. The entire drive station together with the inspection door can be dismantled for easy maintenance. The drive consists of a standard geared motor unit mounted on the bracket attached to the side. Suitable safety clutches can be provided to prevent overloads.

The trough consists of individual, standard-length sections with connecting flanges. Hold-down rails are recommended or most of the materials to be conveyed. These prevent the material from building up and thus the chain climbing. For moderately abrasive materials, the side walls and base plate are protected by manganese alloy steel against wear. Fusion-cast basalt linings or liner plates with hard surface welding are recommended for use with highly abrasive materials. In special cases, the trough floor can be designed to act as a material pad.

The take-up station has flange bearings to hold the take up shaft. The shaft exit points in the housing are equipped with grease



filled, double radial shaft seals. The entire station together with the inspection door can be dismantled for easy maintenance. The chain take-up is generated and set by spring-loaded pressure screws.

The driving and return sprockets are highly wear-resistant and have interchangeable, hardened toothed segments.

The standard conveyor chains used are forged, fork-sprocket chains that have been heat-treated or case-hardened.

The resistance to wear can be further increased by hard surface welding. Available options are: highly wear resistant RUD round steel chains, bushed transporting chains according to DIN 8165 and block chains.

Standard safety devices, comprising speed governors and take-up screw monitors, detect the operating status of the trough chain conveyor.

Additional accessories are available.

# RUD FORKED-LINK CHAINS

SINGLE // DOUBLE STRAND

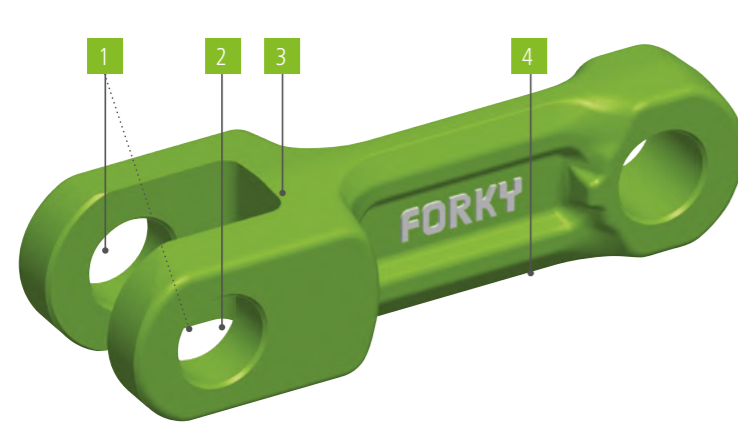

- 1** Bores parallel to the axle with higher graduation accuracy
  - For smoother running and hence
  - For minimum wear
- 2** Deburred bores
  - Even inside the fork for highest endurance strength and reliability
- 3** Extra large radii
  - For more stability of the fork

High quality and safety

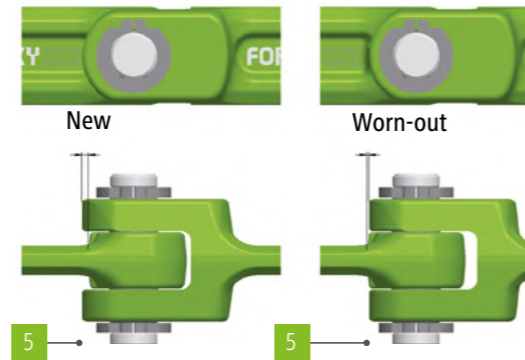

- 4** Tensioning-optimised bar form
  - For high lateral stiffness
- 5** Optical wear indicator
  - The wear condition can be recorded at a glance at every individual chain link

## FORKY – SINGLE STRAND

Size	Weight (kg)	Breaking force*[kN]	T (mm)	H (mm)	B (mm)	B <sub>g</sub> (mm)	B <sub>n</sub> (mm)	S (mm)	D (mm)
142 × 50 × 19	1,4	300	142	50	19	42	20	13	25
142 × 50 × 29	2,0	480	142	50	29	62,5	30	15	25
260 × 75 × 31	5,3	700	260	75	31	70	32	18	32

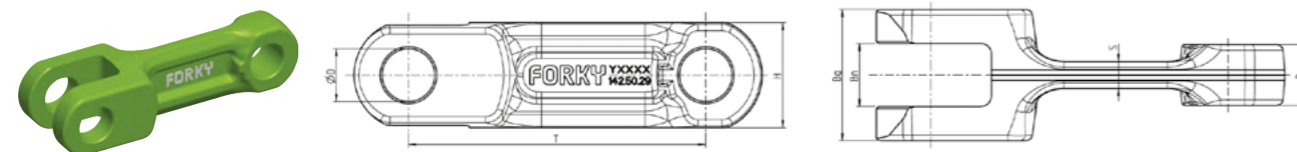

## FORKY – DOUBLE STRAND

Size	Weight (kg)	Breaking force*[kN]	T (mm)	H (mm)	B (mm)	B <sub>g</sub> (mm)	B <sub>n</sub> (mm)	S (mm)	D (mm)	N (mm)
142 × 50 × 19	1,7	300	142	50	19	42	20	13	25	12,5
142 × 50 × 29	2,3	480	142	50	29	62,5	30	15	25	12,5
200 × 50 × 25	2,7	350	200	50	25	58	26	17	25	12,5
250 × 60 × 30	4,7	520	250	60	30	70	31	20	30	12,5

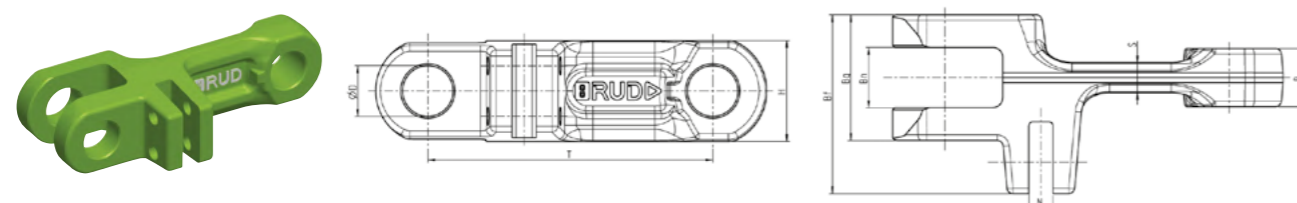

\* Theoretical value for case-hardened forked-link chains

# RUD ATTACHMENTS COMPONENTS

WHEELS // SPROCKETS

## Attachments for single strand forked-link chains FORKY – types of attachments \*

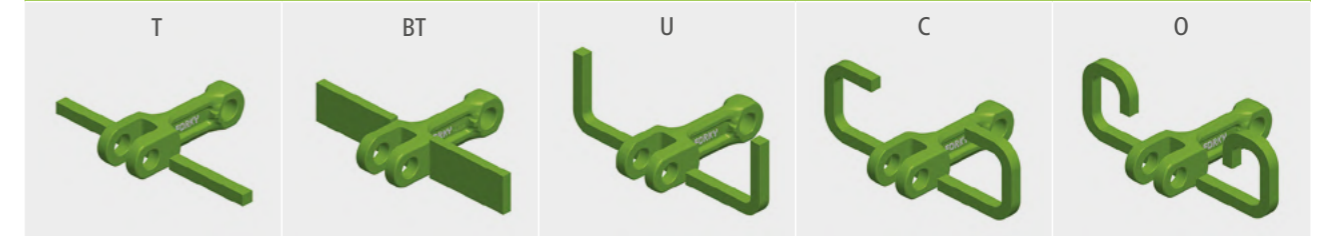

## Attachments classification



## Attachments for double strand forked-link chains FORKY – types of attachments \*



## Attachments classification

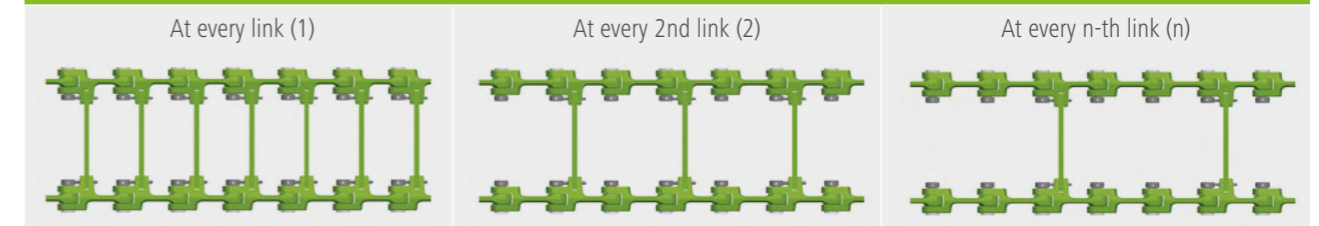

\* All the attachment types can also be delivered with welded plates as per your specification! All types on request!

Forked-link chains are suitable for transporting powdered, flaky, grainy and fragmentary bulk materials, but not for sticky or baking bulk materials.

- Advantages:
- Simple and robust construction, high operational safety
  - Lower space requirement
  - Horizontal, inclined and vertical conveyor possible
  - Explosion safety through slow conveyance without recirculating the material

- Disadvantages:
- Limitation of use regarding suitable conveyance materials
  - No chunky, fibrous or sticky bulk materials

Examples:  
Flour, cement, grains, sugar, chemicals, chipped wood, chips, foodstuff, animal feed etc.

<p>Drive wheels for forked-link chain <b>FORKY</b></p> <p>Properties:</p> <ul style="list-style-type: none"> <li>· Multi-part design</li> <li>· Tooth flanks inductively hardened</li> <li>· The sprocket elements can be swapped at the hubs fitted</li> </ul>	<p>Reversion wheels for forked-link chain <b>FORKY</b></p> <p>Properties:</p> <ul style="list-style-type: none"> <li>· Single-part design</li> <li>· Contact surface inductively hardened</li> </ul>
---	--

# RUD TROUGH CHAIN CONVEYOR

WITH RUD FORK LINK CHAIN FORK

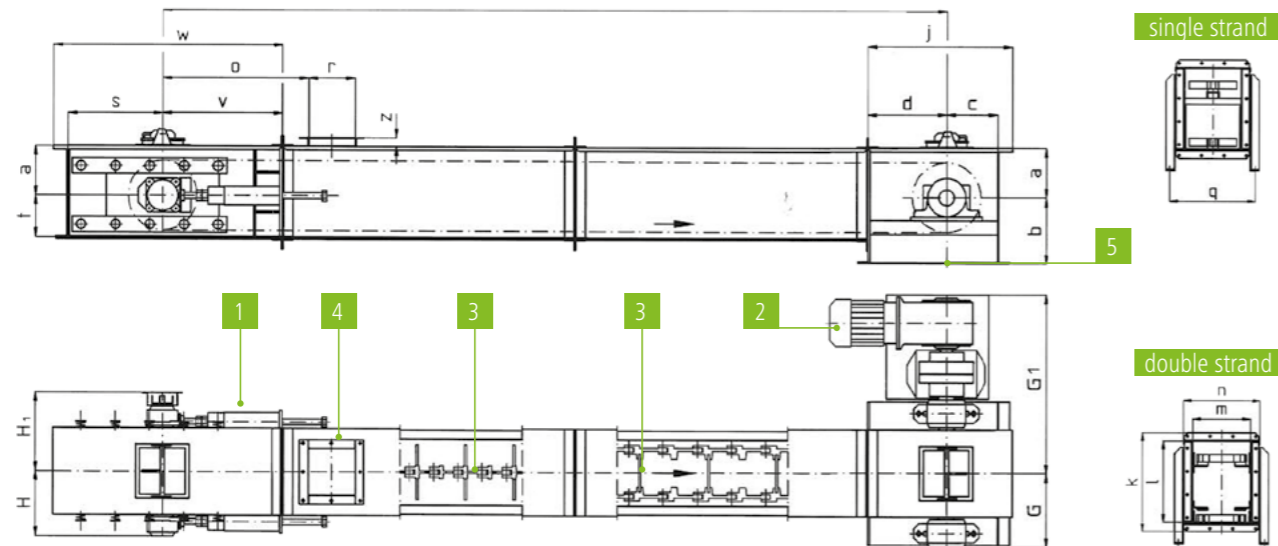

## Trough chain conveyor

- 1 Tensioning station
- 2 Drive station
- 3 Conveyor chains
- 4 Feeding
- 5 Discharge

## AVAILABLE TYPES:

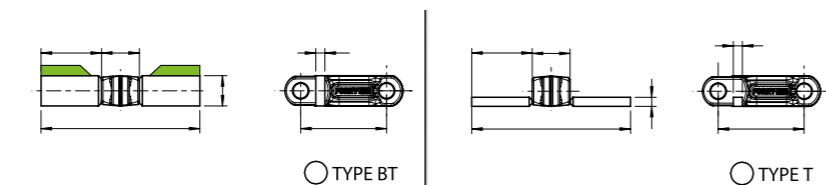

Type T for horizontal and low ascending transport max 10°  
 Type BT for horizontal and low ascending transport, dusty, free flowing material  
 ▲ Type BT special (height up to 1,75 x fork link height), also for high ascending transport max 30°

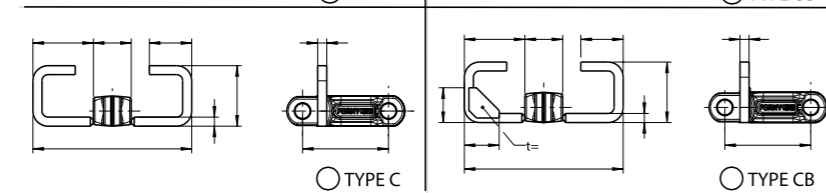
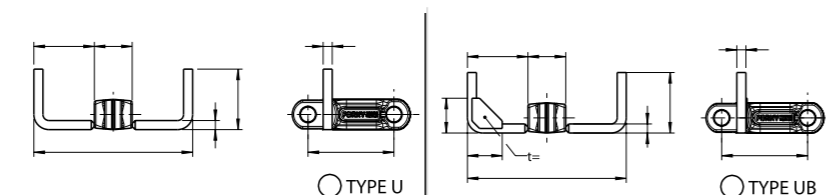

Type U and UB (UB is custom-made) for high ascending transport, 10° up to 25°  
 Type C and CB (CB is custom-made) for high ascending transport and dusty material, 10° up to 25°

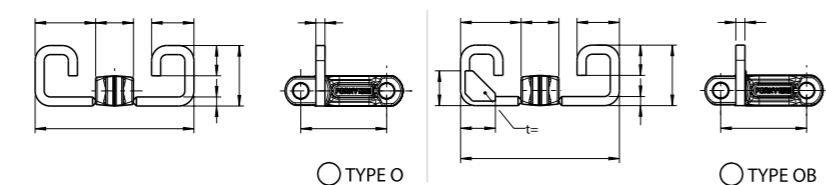

Type O and OB (OB is custom-made) for very high ascending transport, 25° up to 90°  
 Type C, CB, O and OB primarily for vertical transport

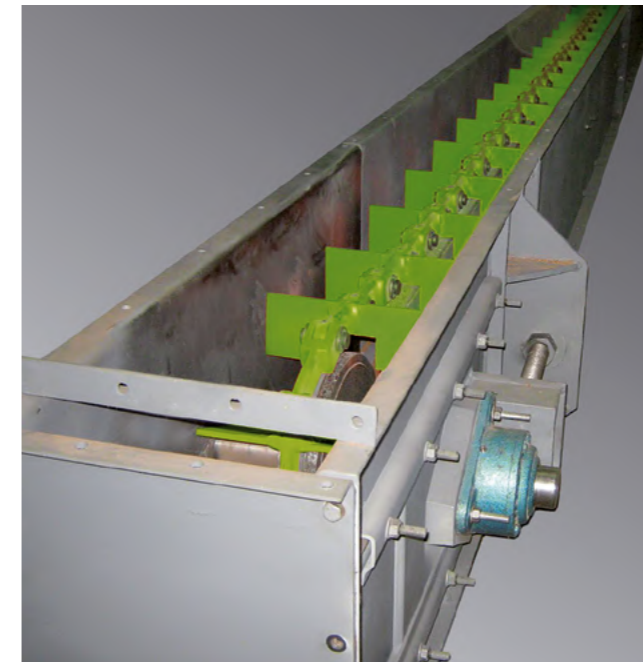

## APPLICATIONS FOR RUD FORK LINK CHAINS:

**Condition of conveyed goods:**  
 RUD fork link chains are ideally suited for transporting powdery, grainy, flaky, dusty or fragmentary material

**Application:**  
 Construction, wood, paper, plastic, food and feed industry, chemical industry, mills, port cargo handling, agriculture and recycling industry

**Examples of transported material:**  
 Cement, clinker, ash, wood chips, wood shavings, food and animal feed, recycled municipal waste fertiliser, gypsum, coke

## CONVEYING SPEEDS [M/S] (MAX. VALUES)

Material	Speed
Grain	1,10
Granulated material	0,80
Coal, chips, soda	0,50
Cement, phosphate, gypsum	0,25
Clinker, petrol coke, potash	0,20
Filter dust, pyrite	0,10
Ash, coke, sand, quartz	0,05



# RUD SCREW CONVEYOR

## TROUGH SCREW CONVEYOR // TUBULAR SCREW CONVEYOR

Long-lasting, easy to maintain screw conveyors are used for the dust-free, horizontal, inclined and vertical transport of fine grained and floury materials. Suitable adaptations are made to handle coarse-grained, higher temperature, abrasive or poorly flowing materials. Screw conveyors also offer the option of multiple inlets and outlets. Various versions handle not only the transport of bulk materials but also emptying, metering, loading, screening and mixing.

### TROUGH SCREW CONVEYOR

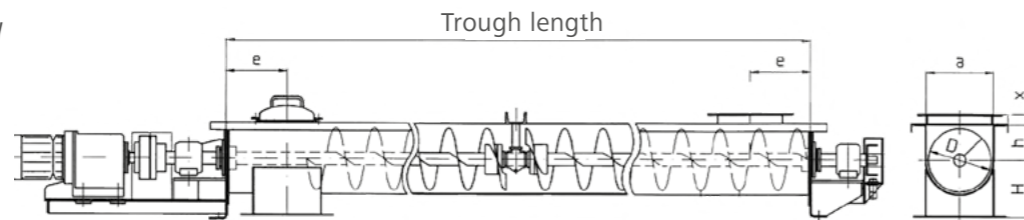

Conveying capacities for horizontal conveyors, reference values for approx. 35% filling

Diameter [mm]	D	200	250	315	400	500	630	800	1000	1250
Speed	[U/min]	100	90	80	71	63	50	40	32	25
Conveyance capacity	[m³/h]	9	17	34	59	93	136	195	281	393

Dimensions

Diameter [mm]	D	200	250	315	400	500	630	800	1000	1250
Trough	a	220	270	335	425	525	660	830	1040	1290
	h	112	140	180	224	280	355	450	560	710
	x	52	52	52	53	53	63	74	74	84
	H	190	225	265	315	375	450	560	670	800
	e	200	240	280	330	390	470	560	680	820

### TUBULAR SCREW CONVEYOR

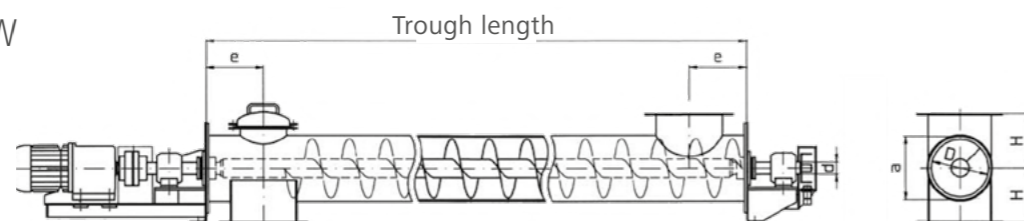

Conveying capacities for horizontal conveyors, reference values for approx. 50% filling

Diameter [mm]	D	140	190	240	290	370	470	570
Speed	[U/min]	112	100	90	80	71	63	50
Conveyance capacity	[m³/h]	5	13	23	45	81	131	195

Dimensions

Diameter [mm]	D	140	190	240	290	370	470	570
Tube-shaped trough	a	160,3	210,1	263	312,7	393,8	495,4	595,4
	h	160	190	225	265	315	375	450
	e	170	200	240	280	330	390	470

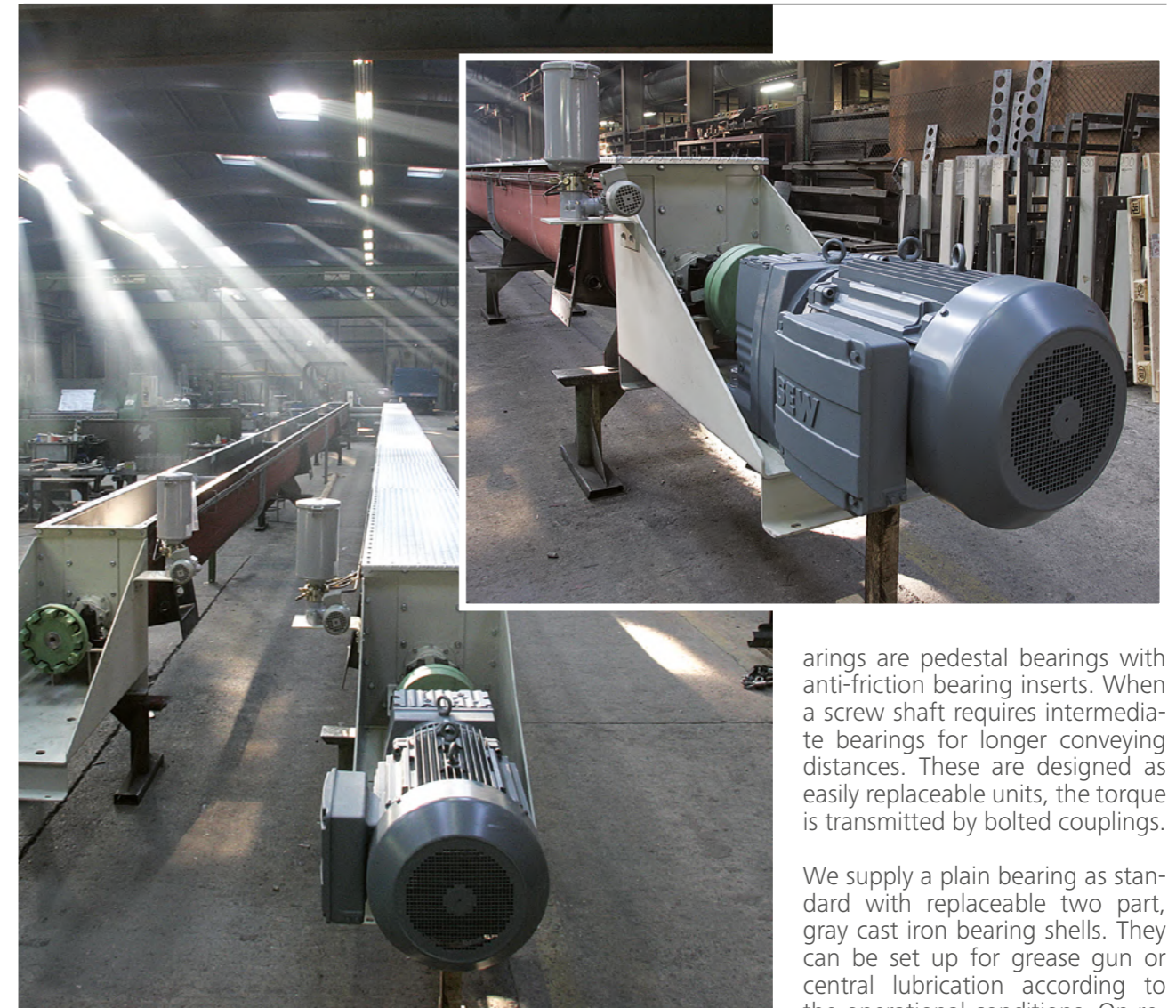

arings are pedestal bearings with anti-friction bearing inserts. When a screw shaft requires intermediate bearings for longer conveying distances. These are designed as easily replaceable units, the torque is transmitted by bolted couplings.

We supply a plain bearing as standard with replaceable two part, gray cast iron bearing shells. They can be set up for grease gun or central lubrication according to the operational conditions. On request, we also supply antifriction bearings with split roller bearings in a sealed, grease-filled suspended housing. The drive comprises a standard geared motor unit.

As a safety device, a speed governor detects the operational status of the screw conveyor.

Additional accessories are available.

The conveyor trough in trough screw conveyors is manufactured as a torsionally rigid sheet metal housing made of standard section lengths with connecting flanges, to which are bolted sturdy cover plates, there is also an inspection door above the outlet. Abrasive materials can be handled by using manganese alloy steel, hard surface welding, fusion cast basalt linings or material padding. Split end walls are bolted to the ends of the trough. This makes it easy to dismount the screw shaft once the metal cover plates have been removed.

The conveyor trough in tubular screw conveyors consists of a stable tube with an inspection door above the outlet. One-piece end walls are bolted to the ends of the trough. These are suitable for supporting the conveyor. Intermediate supports are only required about every 6 meters. They are supplied loose for mounting during assembly. The shaft exit points are usually sealed by gray cast iron stuffing boxes.

The screw shaft is designed as a solid shaft or a rigid tubular shaft with integrated end journals and a welded-on screw thread. The end be-

# GENERAL INSTRUCTIONS

## INSTALLATION AND OPERATION

The adjustability of the deflection should at least be 3 link divisions (compensation of the setting process when running the chain or when chain abrasion takes place).

The usable tensioning distance should be determined after taking into account the length of the loop and the aggressive strain, which affects the chain. Securing the round link steel chains against excess strain or getting blocked by coarse or foreign bodies by means of suitable safety coupling, shear pin or on the drive.

When assembling the sprocket wheels or pulley blocks as well as when manufacturing buckets / bucket attachment and when attaching insertion rails at the return station, accurate adherence to installation dimension and tolerances specified in the respective installation drawings is the prerequisite of proper functioning.

Adhere to the constant initial tension using springs or weights in adjustable tensioning devices, where the size of the chain pre-tensioning force must be coordinated as per the specifications of the respective conveyor. During their complete service life, the chains must be under the correct initial tension. Loose chains give rise to difficulties.

During all the system constructions, the corresponding accident prevention regulations must be considered.

The bulk material to be transported must be supplied in such a way that equal distribution is ensured across the width of the buckets / scraper bar width and all the chain loops are equally tensioned through the bulk material and the tractive force. In case of lateral feed, corresponding precautions must be taken.

Unequal loop stress leads to unequal increase in division due to the wear of individual chain loops; this results in the slanting of the buckets / scraper bars, which in turn results to faults at the return station.

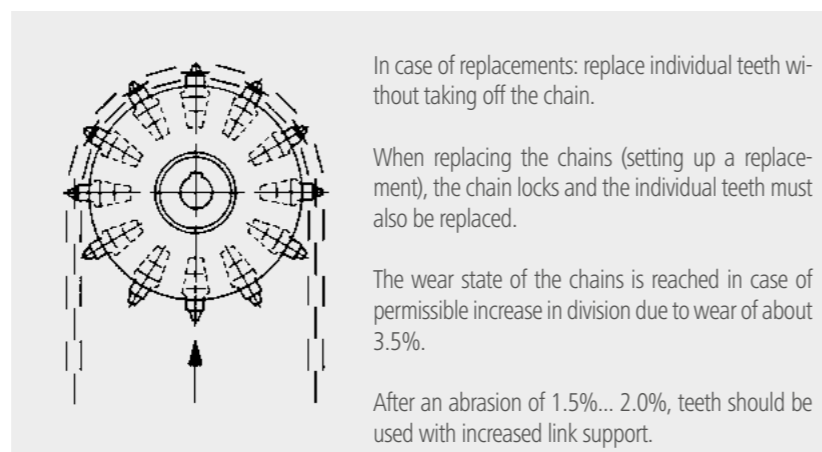
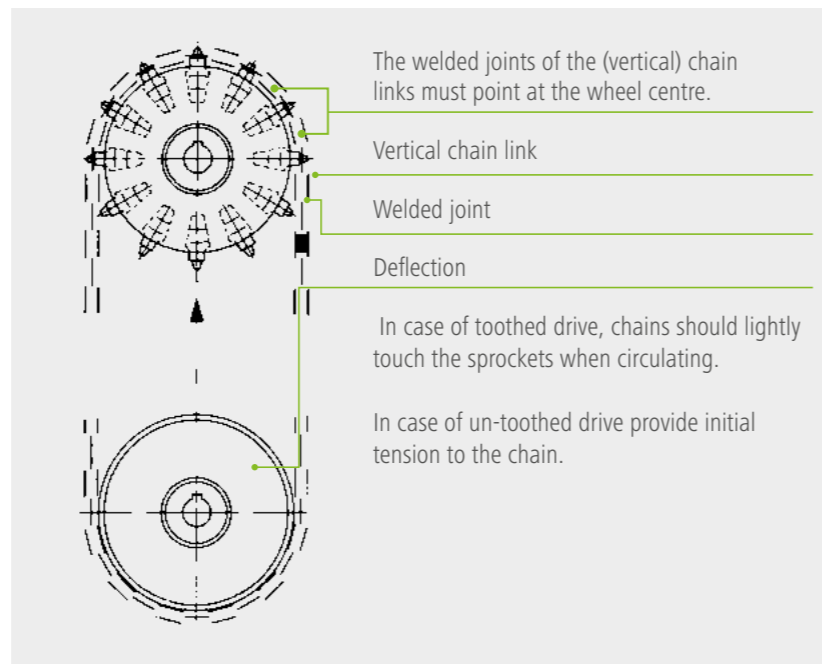
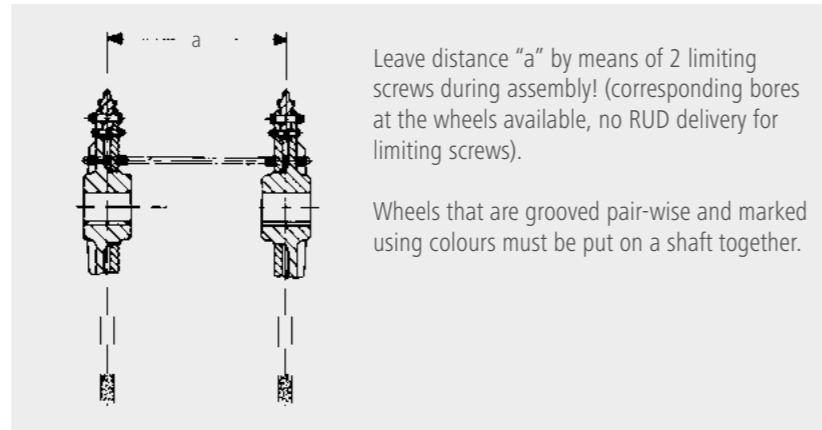

# MAINTENANCE & MONITORING

## ASSEMBLY INSTRUCTIONS FOR RUD CONVEYOR SYSTEMS

RUD conveyor chains – highly wear-resistant– are hard-wearing due to their simple structure assembly and hence require very little maintenance. The following points must be observed with regard to high operational safety:

**Lubrication:** RUD conveyor chains – highly wear-resistant – do not normally require lubrication. Such chains may however be lubricated with standard engine oil (not grease), which do not come in contact with the bulk material or aggressive dusts etc. and hence formation of lubrication gel paste in the joints cannot be safely ruled out. Dirty chains should be cleaned before re-lubrication.

**Initial tension:** The chain tensioning must be checked periodically, especially during the start-up phase of new chains and / or in case of large loop lengths. It must be tensioned only to the extent necessary for the proper functioning of the chain and carriers during normal operating conditions. In case of multi-belt conveyors, the initial tensioning force of all the chain loops must be equal. Unnecessary high initial tensioning force reduces the service life.

**Monitoring:** Chains, locks, wheels, sprockets and flange parts must be checked at periodic intervals for damages, corrosion and unusual wearing parts, and the conveyor elements for deflection and the like. While doing so, attention must be paid to the state of the wearing and safety parts. Damages detected must be immediately rectified.

**Wear:** Round link steel chains and wheel gearing wear out together up to the wear state under normal conditions. This is reached if the chain links at the driving gear run jerkily under stress due to the abrasion to the chain and simultaneous normal chain tensioning or come off suddenly. If the distances between the axis is large, the bulk material is heavily worn out or corroded, in case of high speed, heat influence etc., the chain can run jerkily at the driving gear although the measured increased division due to abrasion is still less than approximately 1.5%. In this case, the wheel gearing is worn out due to the especially high stress and only this must be replaced - but simultaneously at all the driving gears. In principle, the new round link steel chains must only be used along with the new wheel gearing. Round link steel chains, whose average link thickness at any location has reduced by more than 10% of the nominal thickness, must be removed. (average link thickness = mean of 2 dimensions taken perpendicular to each other at the maximum weakened cross-section).

In case of necessary chain reductions, level links must be cut out at the belts to be shortened. Shorten chain belts to odd number of links only, in order to get level starting and final links. The chain links must be carefully cut using cutting discs and without damaging the neighbouring links. Avoid heat influences on links not affected by the cutting at all costs.

**Welding works:** In principle, welding processes should not be carried out at the round link steel chains, chain locks or deeply case-hardened components. It is not permissible to use the chain as earthing connection for electro-welding work at the steel construction.

**In case of single and multi-belt conveyors:** The welded joints of the chain links at the level of the gear must point at the driving gear; the position of the other links is arbitrary. Make sure that the installation position of the chain locks for the sprocket wheels is correct – coach bolt parallel to the sprocket wheel axis (also applicable for pocket wheels and striation sprockets). Install carefully and tighten the screws (strength class 8.8) using torque spanners. After a specific period, re-tighten the screws once again. Assembly for Fa flat lock: link U brackets, hammer in locking bolts and secure with a locking pin

Thread dimension	Tightening torque	
	(Nm)	(Lbf ft)
M 6	10	7
M 8	25	18
M 10	49	35
M 12	85	62
M 14	135	98
M 16	210	152
M 18	300	217
M 20	425	307
M 22	580	420
M 24	730	528
M 27	1100	796
M 30	1450	1049
M 33	1900	1374
M 36	2450	1772

Permissible screw tightening torques for screw quality class 8.8 with total drive value  $\mu_{ges.} = 0.14$ .

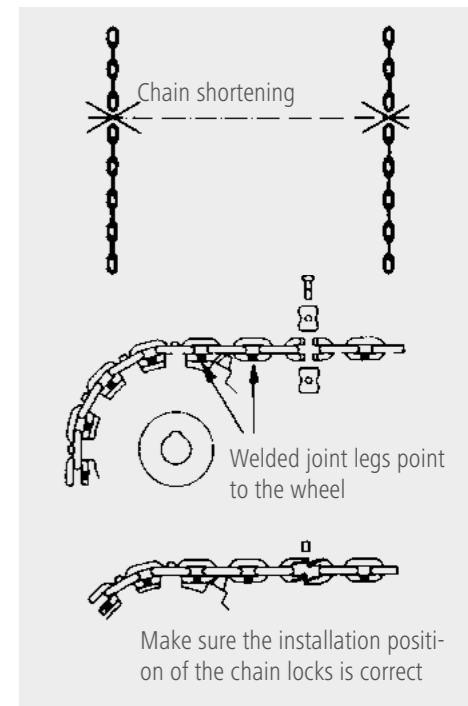

# TECHNICAL QUESTIONNAIRE FOR CONVEYOR SYSTEMS

TEL.: +49 (0) 7361 504-1457  
CONVEYOR@RUD.COM

## SKETCHES

### FOR SCRAPER BARS

Company: \* \_\_\_\_\_ Name: \* \_\_\_\_\_  
 Street: \* \_\_\_\_\_ E-Mail: \* \_\_\_\_\_  
 Post Code: \* \_\_\_\_\_ City: \* \_\_\_\_\_  
 Telephone: \* \_\_\_\_\_

Project: \_\_\_\_\_  New construction  Reconstruction  
 Bulk material: \* \_\_\_\_\_  
 Bulk material bulk density [t/m<sup>3</sup>]: \* \_\_\_\_\_  
 Bulk material properties  
 Corrosion:  high  medium  none  
 Abrasion:  high  medium  none  
 Granularity / dimension: \_\_\_\_\_ mm max. \_\_\_\_\_ mm min.  
 Moisture content: \_\_\_\_\_ Temperature [°C]: \_\_\_\_\_  
 Conveyance capacity max. [t/h]:\* \_\_\_\_\_ Speed [m/s]: \_\_\_\_\_  
 Daily operating hours [h]: \_\_\_\_\_ Annual operating hours [h]: \_\_\_\_\_

Dimension between axes [m]: \* \_\_\_\_\_ Trough width [mm]: \* \_\_\_\_\_ or conveyor width [mm]: \* \_\_\_\_\_  
 Conveyor:  on lower run  on upper run  
 Assignment of material to be transported:  regular  irregular  
 FType of conveyor:  Ash remover  Coaling  Trough conveyor  Bunker discharge

Chain centre distance [mm]: \_\_\_\_\_ Drive power requirement [kW]: \_\_\_\_\_  
 Chain sprocket diameters [mm]: \_\_\_\_\_ Max. operating force / chain strand [kN]: \_\_\_\_\_

Scraper bars:  ja  nein  
 (Scraper bar outline on the following page 67)

Line profile: \*  
 Please add detailed drawing  
 with the necessary dimensions!

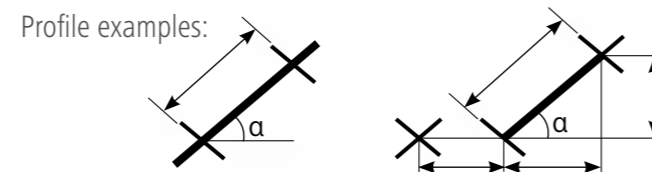

Additional specifications / Additions: \_\_\_\_\_

Annexes / Drawings / Pictures: \_\_\_\_\_

Clear through width of the conveyor [mm]: \_\_\_\_\_ Through bottom material  
 Granite / Basalt  Hardox  Wearing rails  
 Chain centre distance [mm]: \_\_\_\_\_

Additional information / additions to questionnaire conveyors (Page 66)

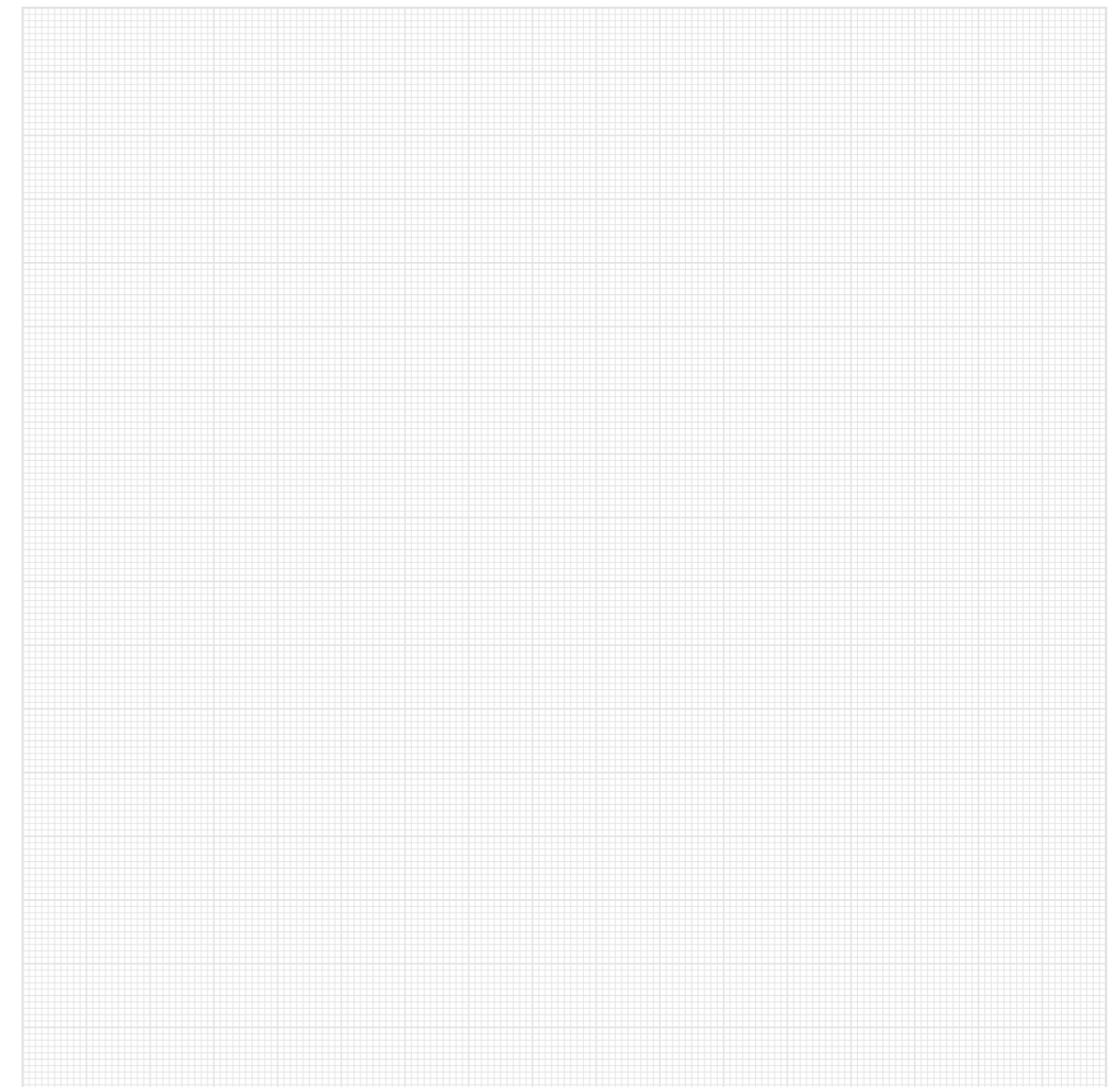

# SOI 1/2

DIMENSION SHEET

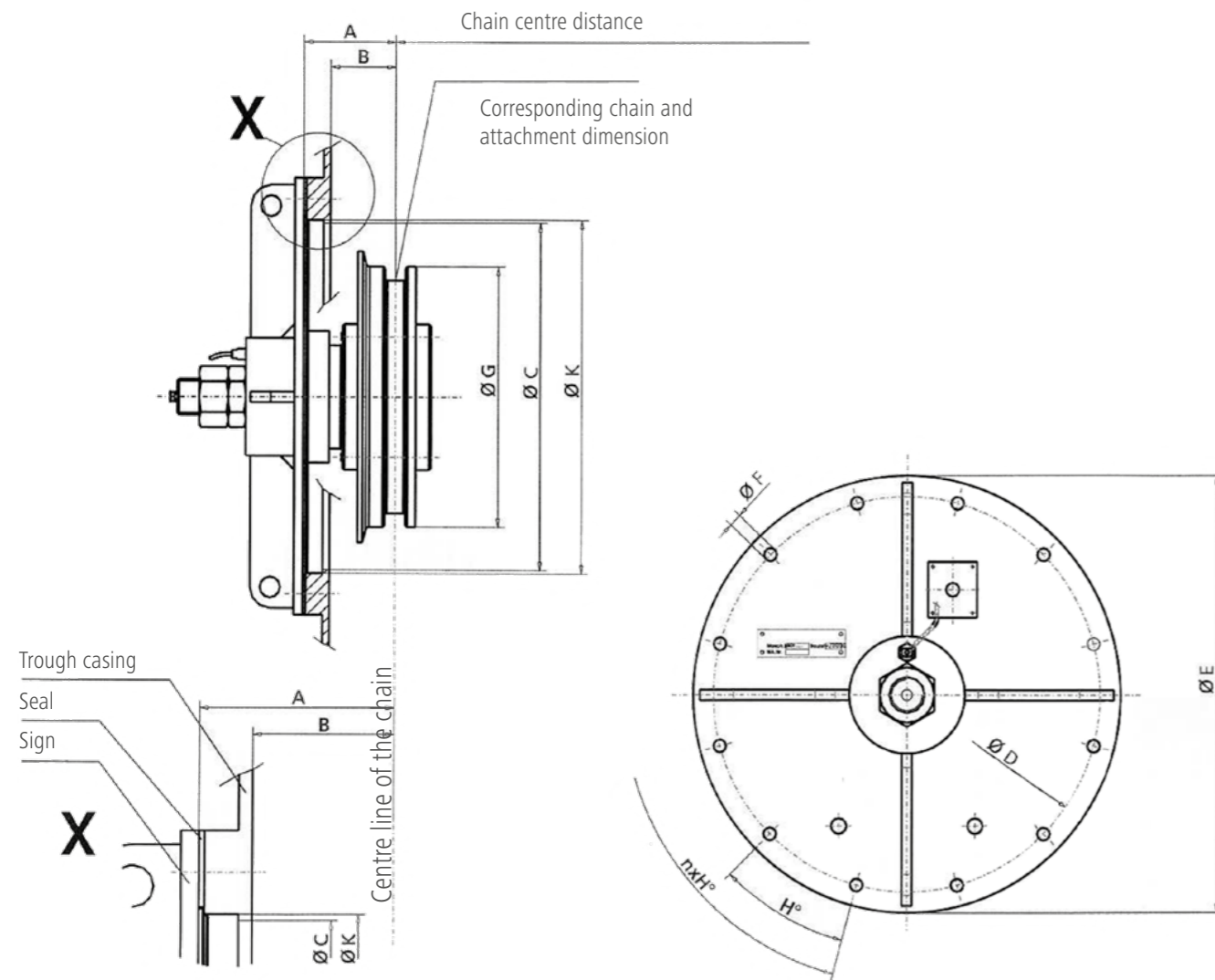

Connecting and functional dimensions

Dimension mm	n (number of bores in the plate):
A	
B	
Ø C	Chain type and dimension:
Ø D	
Ø E	
Ø F	Attachment type and dimension:
Ø G	
H°	
Ø K	

# SOI 2/2

DIMENSION SHEET

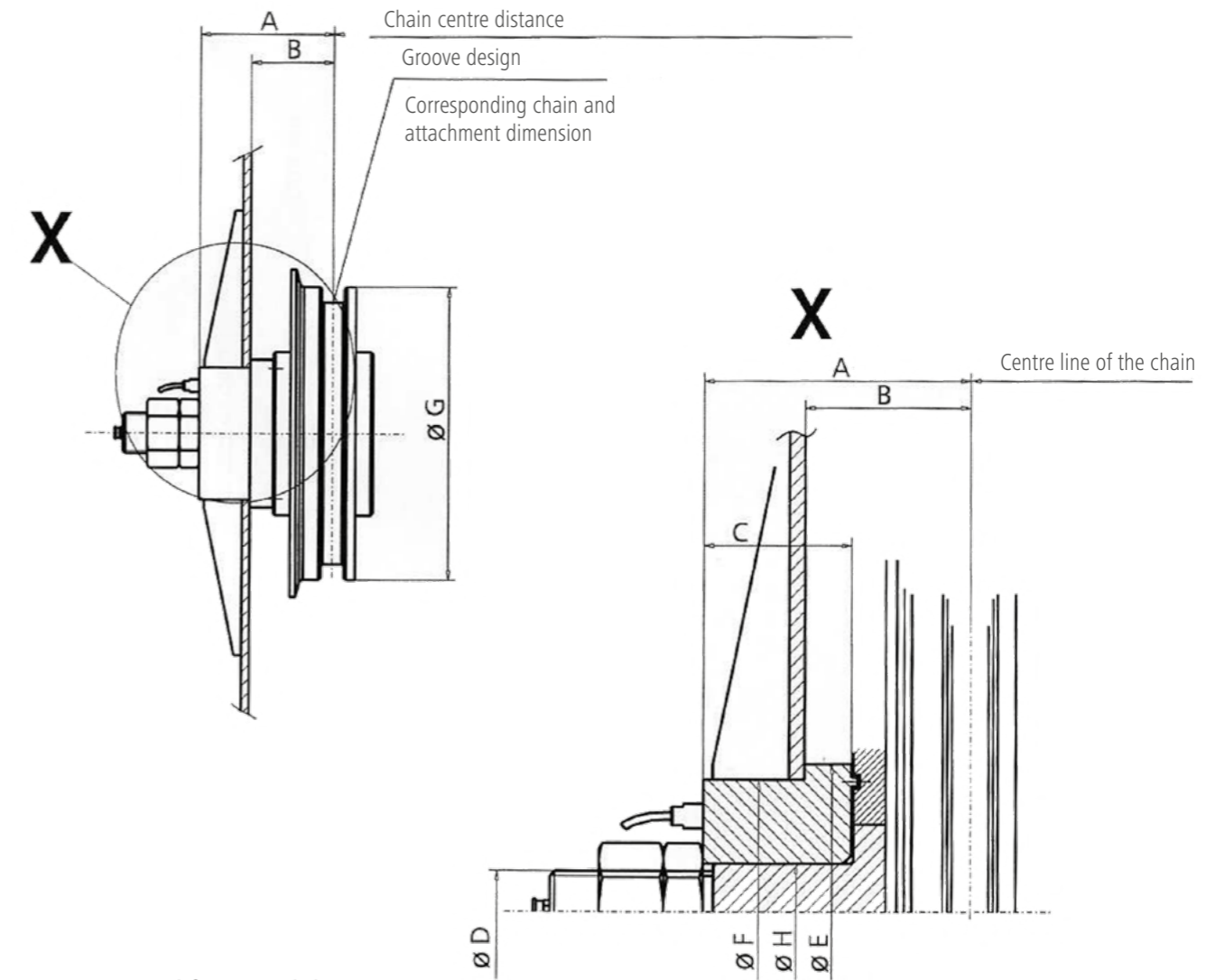

Connecting and functional dimensions

Dimension mm	Chain type and dimension:
A	
B	
C	
Ø D	Attachment type and dimension:
Ø E	
Ø F	
Ø H	

TEL.: +49 (0) 7361 504-1457  
CONVEYOR@RUD.COM

# REVERSING WHEEL TYPE A-B-C

## HUBS / BORE DIMENSIONS

## TECHNICAL QUESTIONNAIRE FOR

# BUCKET ELEVATOR & COMPONENTS

BUCKET CONVEYORS: TEL.:  
+49 (0) 531 23 729-14  
VERTRIEB@HERFURTH-ENGELKE.DE  
COMPONENTS:  
TEL.: +49 (0) 7361 504-1457  
CONVEYOR@RUD.COM

Company: \* \_\_\_\_\_ Name: \* \_\_\_\_\_  
Street: \* \_\_\_\_\_ E-Mail: \* \_\_\_\_\_  
Post code: \* \_\_\_\_\_ City: \* \_\_\_\_\_  
Telephone: \* \_\_\_\_\_

Project: \_\_\_\_\_  New construction  Reconstruction  
Bulk material designation: \* \_\_\_\_\_  
Bulk material bulk density [T/dm<sup>3</sup>]: \* \_\_\_\_\_  
Granularity / dimension: \* \_\_\_\_\_ mm max. \_\_\_\_\_ mm min.  
Moisture content: \_\_\_\_\_ Temperature [°C]: \_\_\_\_\_  
Conveyance capacity max. [t/h]: \* \_\_\_\_\_ Speed [m/s]: \_\_\_\_\_  
Daily operating hours [h]: \_\_\_\_\_ Annual operating hours [h]: \_\_\_\_\_  
Dimension between axes [m]: \* \_\_\_\_\_ Mounting of buckets: \*  shouldered  lateral Bucket designation: \_\_\_\_\_  
Bucket designation: \* \_\_\_\_\_  
Bucket content [l]: \* \_\_\_\_\_ Bucket weight [kg]: \* \_\_\_\_\_  
Axle drive shaft rotation [U/min]: \_\_\_\_\_ Diameter drive shaft [mm]: \_\_\_\_\_  
Diameter of sprocket wheels [mm]: \_\_\_\_\_ Diameter expansion shaft [mm]: \_\_\_\_\_

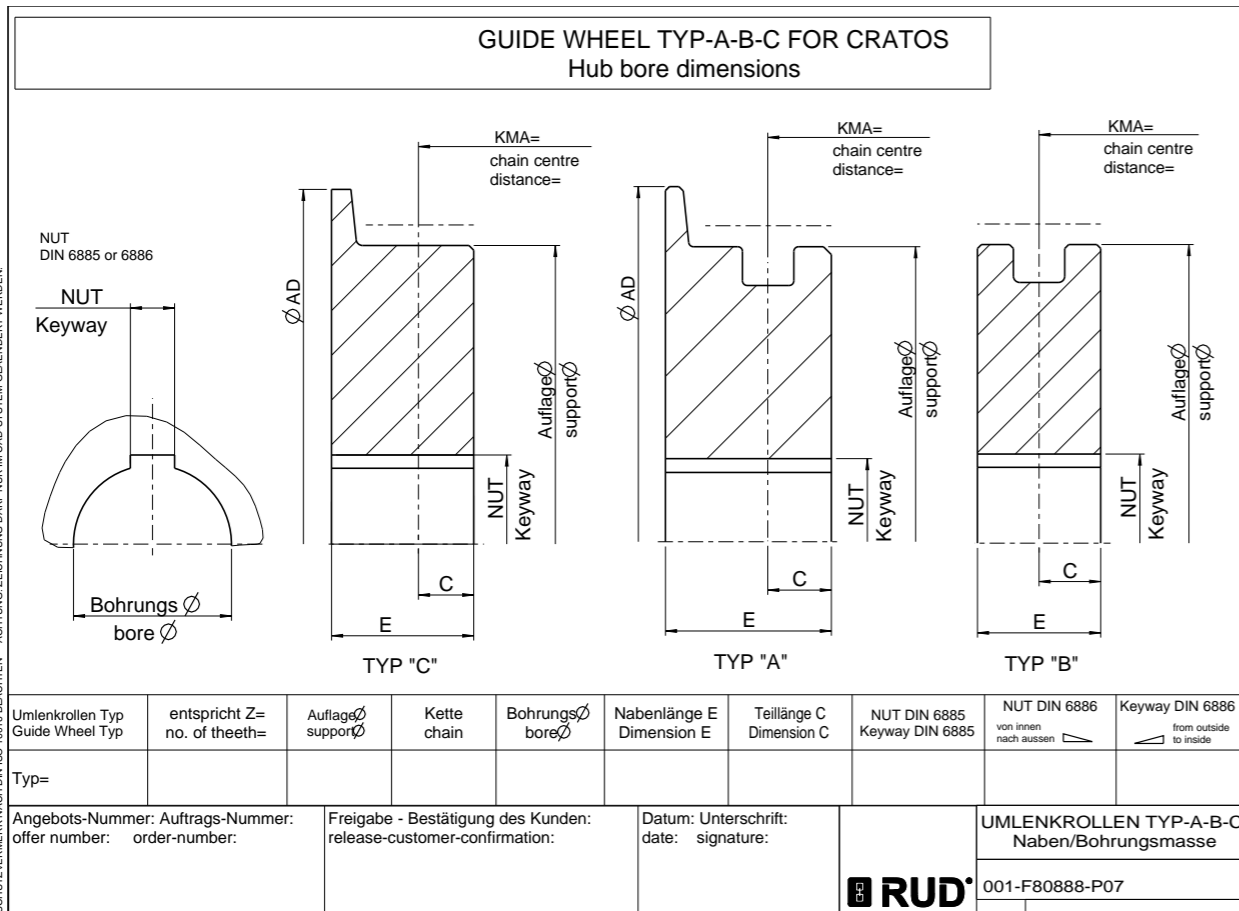

Please add the drawing of the bucket conveyor and the bucket.

Bucket attachment:

RUca  System 65  System2win  System SWA  System Central Chain  
 other bucket attachment (e. g. DIN)

Supplier / Manufacture actual \_\_\_\_\_

Bucket specification (please add the dimensioning)

Bucket width

Bucket type 1

Bucket type 2

Casing dimension: (please add the dimensioning)

Case cavity

Double cavity

Additional specifications / drawings / pictures / additions (f. e. customer issues, target, project, extended settings)

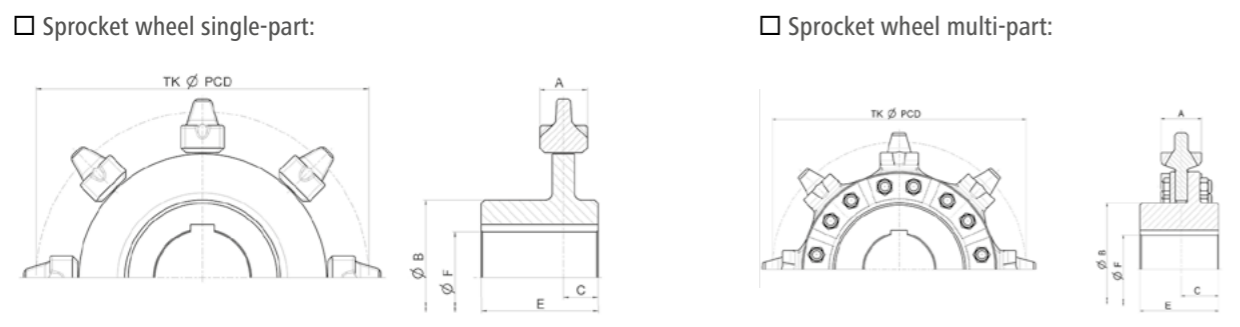

# TECHNICAL QUESTIONNAIRE FOR TROUGH CHAIN CONVEYOR / SCREW CONVEYOR

TEL.: +49 (0) 531 23 729-14  
VERTRIEB@HERFURTH-ENGELKE.DE

# TECHNICAL QUESTIONNAIRE FOR FORKEDLINK CHAINS

TEL.: +49 (0) 7361 504-145  
CONVEYOR@RUD.COM

Company: \* \_\_\_\_\_ Name: \* \_\_\_\_\_  
 Street: \* \_\_\_\_\_ E-Mail: \* \_\_\_\_\_  
 Post code: \* \_\_\_\_\_ City: \* \_\_\_\_\_  
 Telephone: \* \_\_\_\_\_

Project \_\_\_\_\_

Conveyed material: \* \_\_\_\_\_

Conveyed material properties:

Corrosion:	<input type="checkbox"/> strong	<input type="checkbox"/> medium	<input type="checkbox"/> none
Abrasion:	<input type="checkbox"/> strong	<input type="checkbox"/> medium	<input type="checkbox"/> none

Grain size / dimension: \* \_\_\_\_\_ mm

Bulk weight [t/m<sup>3</sup>]: \* \_\_\_\_\_ Temperature [°C]: \_\_\_\_\_

Moisture %: \_\_\_\_\_ Required conveying capacity [t/h]: \* \_\_\_\_\_

Conveying speed [m/s]: \_\_\_\_\_

Total daily running time [h]: \_\_\_\_\_ Per year [h]: \_\_\_\_\_

Center distance [m]: \* \_\_\_\_\_ Pitch angle [degrees]: \* \_\_\_\_\_

Trough width [mm]: \_\_\_\_\_

Conveying in lower run \_\_\_\_\_ Conveying in upper run \_\_\_\_\_

Conveyed material feed? Regular: \_\_\_\_\_ Irregular \_\_\_\_\_

a) Line course with indication of the position of the material feed and discharge with dimensions  
 b) Bunker discharge (enclose dimensioned drawing)

Sprocket diameter [mm]: \_\_\_\_\_

Drive power requirement [kW]: \_\_\_\_\_

Max. Operating force per chain strand [kN]: \_\_\_\_\_

New construction  Conversion (specify existing housing dimensions)

For special requirements, please enclose specification or sketch.

Single strand

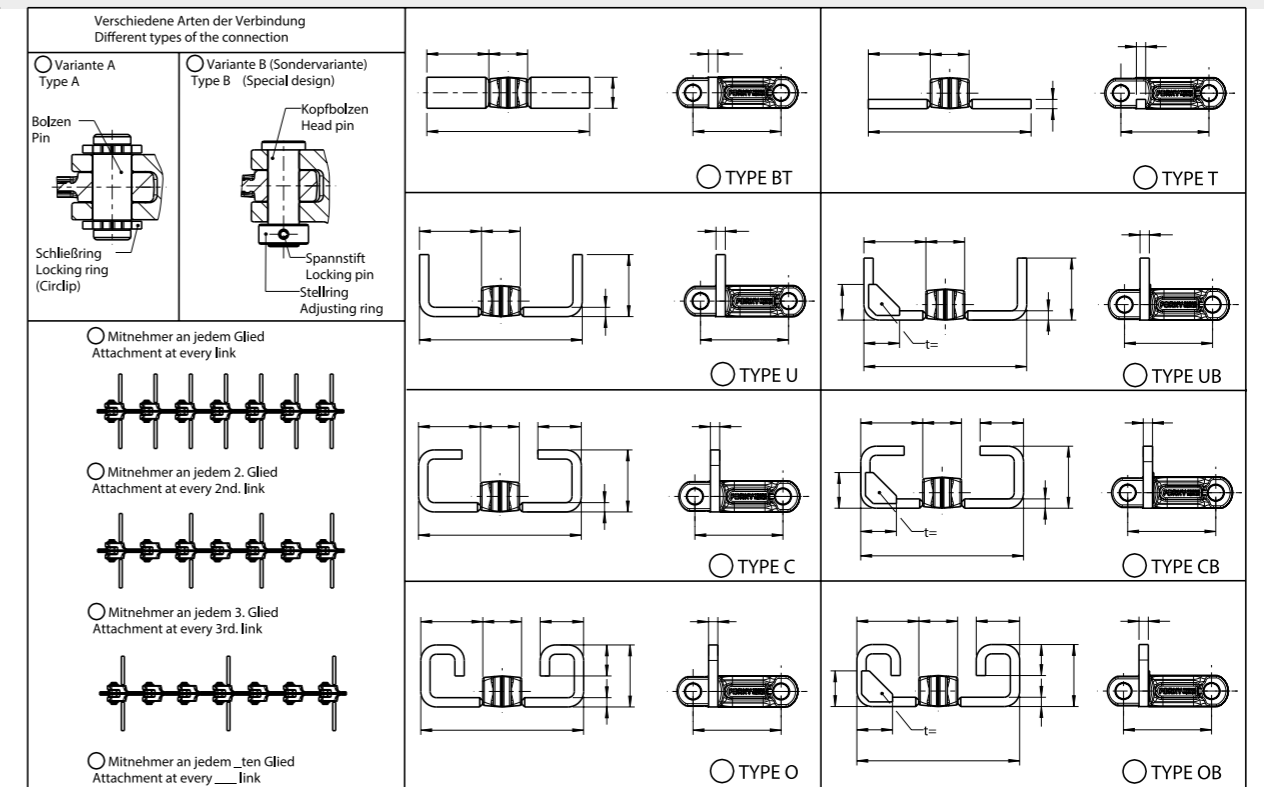

Multiple strand

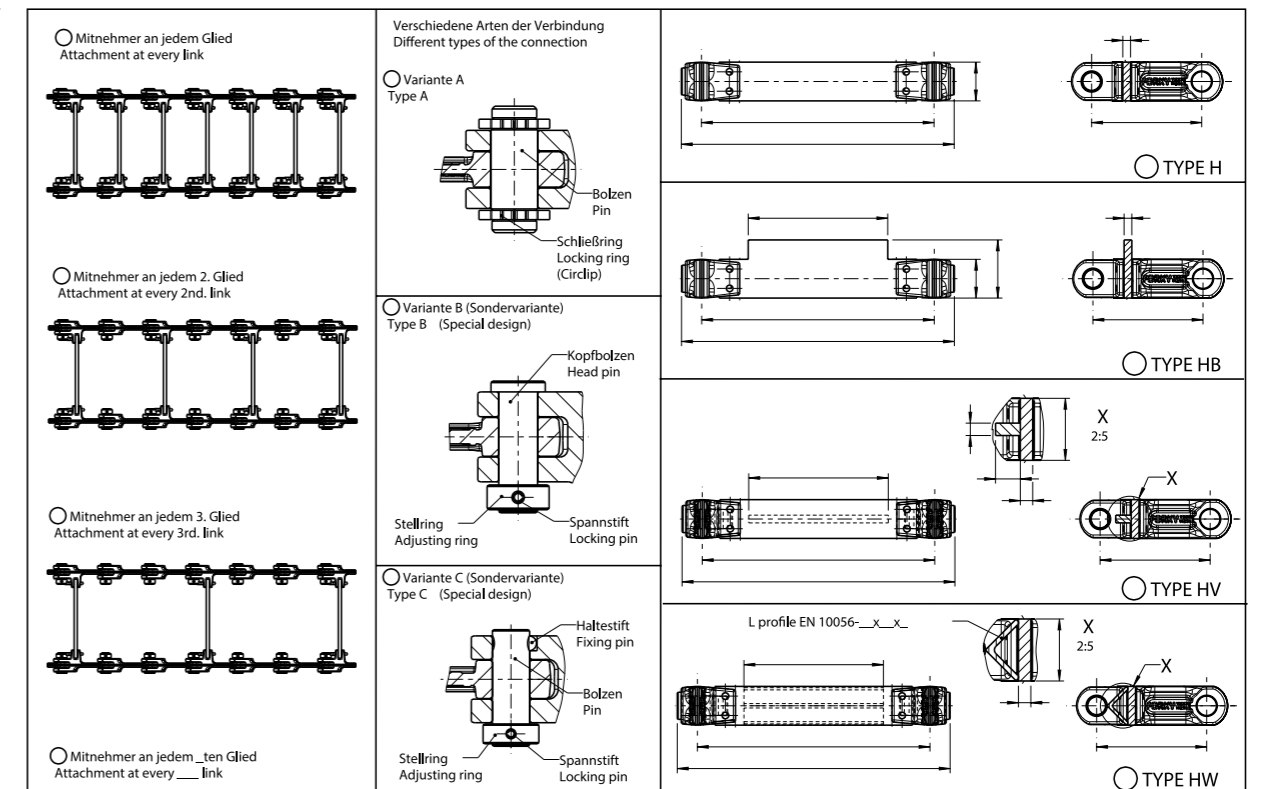

Note: This form contains mandatory fields that must be completed. Mandatory fields are marked with a \* sign.

# TECHNICAL QUESTIONNAIRE FOR FORKED-LINK CHAINS

TEL.: +49 (0) 7361 504-1457  
CONVEYOR@RUD.COM

RUD-ANTRIEBSRAD FORKY RUD-DRIVING WHEEL FORKY  
Naben/Bohrungsmasse Hub bore dimensions

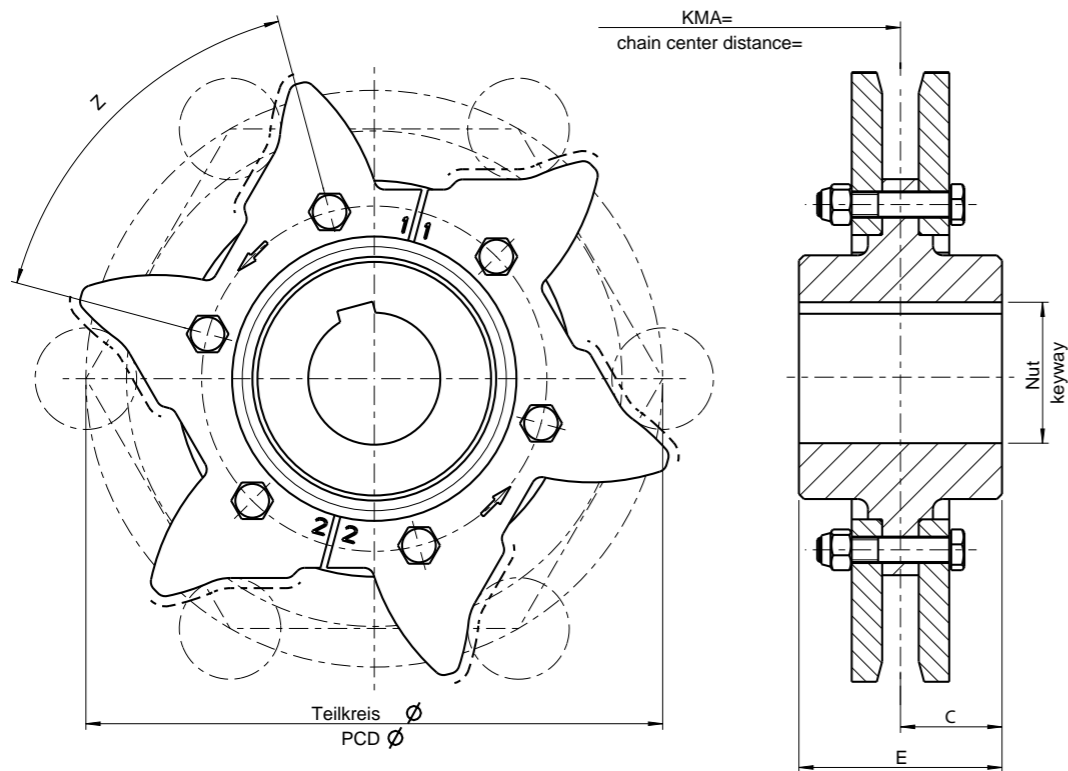

- FORKY Einstrang/FORKY SINGLE STRAND    
  FORKY Doppelstrang /FORKY DOUBLE STRAND    
 Nut/keyway DIN 6885 or 6886

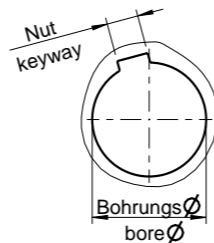
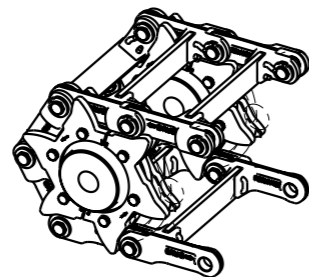
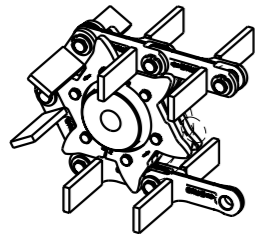

Zahnkettensrad Sprocket wheel	Zähnezahl no. of teeth	Teilkreisdurch- messer Ø PCD Ø	Kette chain	BohrungsØ bore Ø	Nabellänge E Dimension E	Teillänge C Dimension C	Nut DIN 6885 Keyway DIN 6885	Nut DIN 6886 von innen nach aussen	Keyway DIN 6886 from outside to inside	Stellschraube adjusting screw
Angebots-Nummer: Auftrags-Nummer: offer number: order-number:		Freigabe - Bestätigung des Kunden: release-customer-confirmation:			Datum: Unterschrift: date: signature:		erstellt: 12.04.13/JJU geprüft:	FORKY RÄDER/FORKY WHEELS NABEN BOHRUNGSMASSE/HUB BORE DIMENSIONS RUD-CRATOS		
							<b>RUD</b> 001-F80888-P23			

Copyright reserved // Schutzvermerk nach DIN ISO 16016 beachten // Achtung: Zeichnung darf nur im CAD-System geändert werden!



**CONVEYOR & DRIVE  
NORTH AMERICA**

**RUD Conveyor & Drive North America**

29 Prince Andrew Pl, North York, ON M3C 2H2, Canada  
Phone +1 416-900-3271  
Email: [info@rud-cd.com](mailto:info@rud-cd.com)     [www.rud-cd.com](http://www.rud-cd.com)

**USA Warehouse**

2145 Internationale Parkway Suite-800 Woodridge, IL 60517, USA  
Phone: +1 779-232-1846  
Email: [info@rud-cd.com](mailto:info@rud-cd.com)     [www.rud-cd.com](http://www.rud-cd.com)



RUD Ketten

Rieger & Dietz GmbH u. Co. KG  
Friedensinsel  
73432 Aalen / Germany  
Tel. +49 7361 504-1457

Email: [conveyor@rud.com](mailto:conveyor@rud.com) · [www.rud.com](http://www.rud.com)



**RUD Conveyor & Drives**



**RUD TECDOS Mould Handling Solution**

Efficient and safe handling of moulds in the injection moulding industry. We have different solutions for turning, opening and closing that optimise your processes.



**RUD TECDOS Drive Technology**

Rotating, lifting, moving or telescoping - with our drive systems RUD TECDOS OMEGA and RUD TECDOS PI-GAMMA, we offer maximum efficiency and reliability.

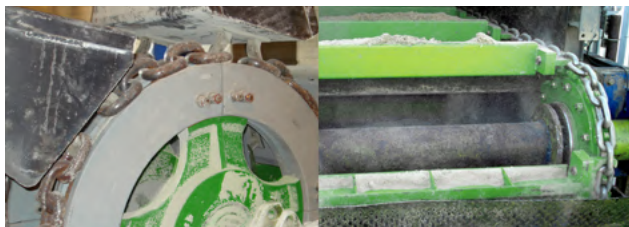

**RUD Conveyor Technology**

Combinable components & individual parts for conveyor technology, conveyor systems and mining. RUD offers you perfectly coordinated systems and components for horizontal, vertical and inclined conveyors.

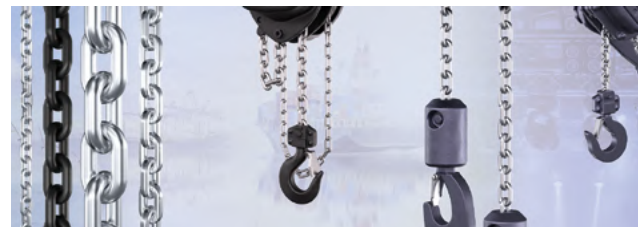

**RUD Industrial Chains**

RUD components are the first choice worldwide for leading hoisting equipment manufacturers. We also offer a wide range of round link chains for different industries and areas, such as food, fishing and awnings.